

MICHIGAN ELECTRIC UTILITY
Generator Interconnection Requirements

***Category 3
Projects with
Aggregate Generator Output
Greater Than 150 kW, but Less Than or Equal to
550 kW***

August 3, 2009



Upper Peninsula Power Company

Introduction

Category 3 – Greater than 150kW less than or equal 550 kW

This Generator Interconnection Procedure document outlines the process & requirements used to install or modify generation projects with aggregate generator output capacity ratings greater than 150kW less than or equal to 550kW and designed to operate in parallel with the Upper Peninsula Power Company (UPPCO) electric system. Technical requirements (data, equipment, relaying, telemetry, metering) are defined according to type of generation, location of the interconnection, and mode of operation (Flow-back or Non-Flow-back). The process is designed to provide an expeditious interconnection to the UPPCO electric system that is both safe and reliable.

This document has been filed with the Michigan Public Service Commission (MPSC) and complies with rules established for the interconnection of parallel generation to the UPPCO electric system in the MPSC Order in Case No. U-15787.

The term “Project” will be used throughout this document to refer to electric generating equipment and associated facilities that are not owned or operated by an electric utility. The term “Project Developer” means a person that owns, operates, or proposes to construct, own, or operate, a Project.

This document does not address other Project concerns such as environmental permitting, local ordinances, or fuel supply. Nor does it address agreements that may be required with UPPCO and/or the transmission provider, or state or federal licensing, to market the Project’s energy. An interconnection request does not constitute a request for transmission service.

It may be possible for UPPCO to adjust requirements stated herein on a case-by-case basis. The review necessary to support such adjustments, however, may be extensive and may exceed the costs and timeframes established by the MPSC and addressed in these requirements. Therefore, if requested by the Project Developer, adjustments to these requirements will only be considered if the Project Developer agrees in advance to compensate UPPCO for the added costs of the necessary additional reviews and to also allow UPPCO additional time for the additional reviews.

UPPCO may apply for a technical waiver from one or more provisions of these rules and the MPSC may grant a waiver upon a showing of good cause.

Table of Contents

INTERCONNECTION PROCESS	5
Customer Project Planning Phase	5
Application & Queue Assignment.....	5
Application Review.....	5
Engineering Review	6
Distribution Study	6
Customer Install & POA	Error! Bookmark not defined.
Meter install, Testing, & Inspection	6
Operation in Parallel.....	7
OPERATIONAL PROVISIONS	7
Disconnection.....	7
Maintenance and Testing.....	7
Technical Requirements	8
MAJOR COMPONENT DESIGN REQUIREMENTS	8
Data	8
Isolating Transformer(s)	9
Isolation Device.....	9
Interconnection Lines.....	10
Termination Structure.....	10
RELAYING DESIGN REQUIREMENTS	10
Protective Relaying General Considerations.....	11
Momentary Paralleling	11
Instrument Transformer Requirements	11
Direct Transfer Trip (DTT).....	12
Reverse Power Relaying for Non Flow-back.....	12
Automatic Reclosing	12
Single-Phase Sectionalizing.....	13
Synchronous Projects	14
General	14
Isolation Transformer and Utility Ground Fault Detection.....	14
Induction Projects	16
General	16
Isolation Transformer and Utility Ground Fault Detection.....	16
Inverter Projects 18	
General	18
DYNAMOMETER PROJECTS	19

GENERAL.....	19
RELAY SETTING CRITERIA.....	20
Maintenance and Testing.....	21
INSTALLATION AND DESIGN APPROVAL.....	22
TELEMETRY AND DISTURBANCE MONITORING REQUIREMENTS.....	23
Operating in Parallel.....	25
Reactive Power Control	26
Standby Power.....	27
System Stability and Site Limitations	27
REVENUE METERING REQUIREMENTS	28
Non Flow-back Projects	28
Flow-back Projects.....	28
APPENDIX A	30
Interconnection Process Flow Diagram.....	30
APPENDIX B	31
Interconnection Table – Applicant Costs.....	31
Combined Net Metering / Interconnection Table - Applicant Costs.....	31
Interconnection Timeline – Working Days.....	31
APPENDIX C - PROCEDURE DEFINITIONS.....	32
APPENDIX D – SITE PLAN.....	36
APPENDIX E – SAMPLE SYNCHRONOUS ONE-LINE	37
APPENDIX F – SAMPLE INDUCTION ONE-LINE.....	39
APPENDIX G – SAMPLE ONE-LINE INVERTER	41
APPENDIX H	43
Sample One Line Diagram for Non-Flow Back projects.....	43
APPENDIX I.....	44
Sample One Line Diagram for Flow-Back projects.....	44

Interconnection Procedures

Interconnection Process

Customer Project Planning Phase

An applicant may contact UPPCO before or during the application process regarding the project. UPPCO can be reached by phone, e-mail, or by the external website to access information, forms, rates, and agreements. UPPCO will provide up to 2 hours of technical consultation at no additional cost to the applicant. Consultation may be limited to providing information concerning the UPPCO system operating characteristics and location of system components.

Application & Queue Assignment

The Project Developer must first submit a combined Interconnection and Net Metering application to UPPCO. A separate application is required for each Project or Project site. The blank Interconnection Application can be found on UPPCO's website.

A complete submittal of the application and the application fee (See Appendix B) will enable the process. UPPCO will notify the Project Developer within 10 business days of receipt of an Interconnection Application. If any portion of the Interconnection Application, data submittal (a site plan and the one-line diagrams), or filing fee is incomplete and/or missing, UPPCO will return the application, data, and filing fee to the Project developer with explanations. Project Developer will need to resubmit the application with all the missing items. Once UPPCO has accepted the combined Interconnection and Net Metering Application, a queue number will be assigned to the Project. UPPCO will then advise the applicant that the application is complete and provide the customer with the queue assignment.

Application Review

UPPCO shall review the complete application for interconnection to determine if an engineering review is required. UPPCO will notify the Project Developer within 10 business days of receipt of complete application and if an engineering review is required. If an engineering review is required, UPPCO will notify the applicant of the need for the Engineering Review. The applicant is exempt from the cost of the engineering review. The applicant shall provide any changes or updates to the application before the engineering review begins. If an engineering review is not required, the project will advance to the **Customer Install & POA**. UPPCO may request additional data be submitted as necessary during the review phase to clarify the operation of the Project.

Engineering Review

UPPCO shall study the project to determine the suitability of the interconnection equipment including safety and reliability complications arising from equipment saturation, multiple technologies, and proximity to synchronous motor loads. UPPCO shall provide in writing the results of the engineering study within the time indicated in the Interconnection Timeline Table Appendix B. If the engineering review indicates that a distribution study is necessary, UPPCO shall notify the applicant the need to perform the distribution study. The fee for the cost of a distribution study is indicated in Tables of Appendix B. If an engineering review determines that a distribution study is not required, the project will advance to the Customer Install & POA phase of the process.

Distribution Study

UPPCO shall study the project to determine if a distribution system upgrade is needed to accommodate the proposed project and determine the cost of an upgrade if required. The applicant is responsible for the cost of the study and upgrades if required. UPPCO shall provide in writing the results of the distribution study including estimated completion timeframe for the upgrades, if required, to the applicant, within the timeframe allowed by the Interconnection Timeline Table Appendix B. If a distribution study determines that a distribution upgrades are not required, the project will advance to the Customer Install & POA phase of the process.

Customer Install & POA.

The applicant shall notify UPPCO when an installation and any required local code inspection and approval is complete. The Parallel Operating Agreement for different rates can be found from UPPCO's customer generation website. The Parallel Operating Agreement will cover matters customarily addressed in such agreements in accordance with Good Utility Practice, including, without limitation, construction of facilities, system operation, interconnection rate, defaults and remedies, and liability. The applicant shall complete, sign and return the POA (Parallel Operating Agreement to UPPCO). Any delay in the applicant's execution of the Interconnection and Operating Agreement will not count toward the interconnection deadlines.

Meter Install, Testing, & Inspection

Upon receipt of the local code inspection approval and executed POA, UPPCO will schedule the meter install, testing, and inspection. UPPCO shall have an opportunity to schedule a visit to witness and perform commissioning tests required by IEEE 1547.1 and inspect the project. UPPCO may provide a waiver of its right to visit the site to inspect the project and witness or perform the commissioning tests. UPPCO shall notify the applicant of its intent to visit the site, inspect the project, witness or perform the commissioning tests, or of its intent to waive inspection within 10 working days after notification that the installation and local code inspections have passed. Within 5

working days from receipt of the completed commissioning test report (if applicable), UPPCO will notify the applicant of its approval or disapproval of the interconnection. If UPPCO does not approve the interconnection, UPPCO shall notify the applicant of the necessary corrective actions required for approval. The applicant, after taking corrective action, may request UPPCO to reconsider the interconnection request.

Operation in Parallel

Upon UPPCO approval of the interconnection, UPPCO shall install required metering, provide to the applicant a written statement of final approval, and a fully executed POA authorizing parallel operation.

Operational Provisions

Disconnection

UPPCO may refuse to connect or may disconnect a project from the distribution system if any of the following conditions apply:

- a. Lack of fully executed interconnection agreement (POA)
- b. Termination of interconnection by mutual agreement
- c. Noncompliance with technical or contractual requirements in the interconnection agreement after notice is provided to the applicant of the technical or contractual deficiency.
- d. Distribution system emergency
- e. Routine maintenance, repairs, and modifications, but only for a reasonable length of time necessary to perform the required work and upon reasonable notice.

Maintenance and Testing

UPPCO reserves the right to test the relaying and control equipment that involves protection of UPPCO's electric system whenever UPPCO determines a reasonable need for such testing exists.

The applicant is solely responsible for conducting and documenting proper periodic maintenance on the generating equipment and its associated control, protective equipment, interrupting devices, and main Isolation Device, per manufacturer recommendations.

Routine and maintenance checks of the relaying and control equipment must be conducted in accordance with provided written test procedures which are required by IEEE Std. 1547, and test reports of such testing shall be maintained by the applicant and made available for UPPCO inspection upon request. [NOTE – IEEE 1547 requires that testing be conducted in accordance with written test procedures, and the nationally recognized testing laboratory providing certification will require that such test procedures be available before certification of the equipment.]

Technical Requirements

Technical Requirements

The following discussion details the technical requirements for interconnection of Category 3 Projects with aggregate generator output greater than 150 kW, but less than or equal to 550 kW. Many of these requirements will vary based on the capacity rating of the Project, the type of generation being used, and the mode of operation (Flow-back or Non Flow-back). A few of the requirements will vary based on location of the interconnection (isolated load and available fault current).

Certain major component, relaying, telemetry, and operational requirements must be met to provide compatibility between the Project equipment and the UPPCO electric system, and to assure that the safety and reliability of the electric system is not degraded by the interconnection. UPPCO reserves the right to evaluate and apply newly developed protection and/or operation schemes at its discretion. All protective functions are evaluated for compliance to IEEE std. 1547. In addition, UPPCO reserves the right to evaluate Projects on an ongoing basis as system conditions change, such as circuit loading, additional generation placed online, etc.

Upgraded revenue metering may be required for the Project.

Major Component Design Requirements

The data requested in Appendix B or C, for all major equipment and relaying proposed by the Project Developer, must be submitted as part of the initial application for review and approval by UPPCO. UPPCO may request additional data be submitted as necessary during the Distribution Study phase to clarify the operation of the Project.

Once installed, the interconnection equipment must be reviewed and approved by UPPCO prior to being connected to the UPPCO electric system and before Parallel Operation is allowed.

Data

The data that UPPCO requires to evaluate the proposed interconnection is documented on a one-line diagram and “fill in the blank” table by generator type in Appendices E, F, or G.

A site plan, one-line diagrams, and interconnection protection system details of the Project are required as part of the application data. The generator manufacturer data package should also be supplied.

Isolating Transformer(s)

If the Project Developer installs an isolating transformer, the transformer must comply with the current ANSI Standard C57.12.

The transformer must have voltage taps on the high and/or low voltage windings sufficient to assure satisfactory generator operation over the range of voltage variation expected on the UPPCO electric system. The Project Developer also needs to assure sufficient voltage regulation at its facility to maintain an acceptable voltage level for its equipment during such periods when its Project is off-line. This may involve the provision of voltage regulation or a separate transformer between UPPCO and the Project station power bus.

The type of generation and electrical location of the interconnection will determine the isolating transformer connections. Allowable connections are detailed under the specific Project type. Note: Some Utilities do not allow an isolation transformer to be connected to a grounded UPPCO system with an ungrounded secondary (UPPCO side) winding configuration, regardless of the Project type. Therefore, the Project Developer is encouraged to consult with UPPCO prior to submitting an application.

The proper selection and specification of transformer impedance is important relative to enabling the proposed Project to meet UPPCO's reactive power requirements (see "Reactive Power Control").

Isolation Device

An isolation device is required and should be placed at the Point of Common Coupling (PCC). It can be a circuit breaker, circuit switcher, pole top switch, load-break disconnect, etc., depending on the electrical system configuration. The following are required of the isolation device:

- Must be approved for use on the UPPCO system.
- Must comply with current relevant ANSI and/or IEEE Standards.
- Must have load break capability, unless used in series with a three-phase interrupting device.
- Must be rated for the application.
- If used as part of a protective relaying scheme, it must have adequate interrupting capability. UPPCO will provide maximum short circuit currents and X/R ratios available at the PCC upon request.

- Must be operable and accessible by UPPCO at all times (24 hours a day, 7 days a week).
- UPPCO will determine if the isolation device will be used as a protective tagging point. If the determination is so made, the device must have a visible open break, provisions for padlocking in the open position and it must be gang operated. If the device has automatic operation, the controls must be located remote from the device.

Interconnection Lines

The physically closest available system voltage, as well as equipment and operational constraints influence the chosen point of interconnection. UPPCO has the ultimate authority to determine the acceptability of a particular PCC.

Any new line construction to connect the Project to UPPCO's electric system will be undertaken by UPPCO at the Project Developer's expense. The new line(s) will terminate on a structure provided by the Project Developer.

Termination Structure

The Project Developer is responsible for ensuring that structural material strengths are adequate for all requirements, incorporating appropriate safety factors. Upon written request, UPPCO will provide line tension information for maximum line dead-end tensions under heavy icing conditions. The structure must be designed for this maximum line tension along with an adequate margin of safety.

Electrical clearances shall comply with requirements of the National Electrical Safety Code and Michigan Public Service Commission Standard 16-79.

The installation of disconnect switches, bus support insulators, and other equipment shall comply with accepted industry practices.

Surge arresters shall be selected to coordinate with the BIL rating of major equipment components and shall comply with recommendations set forth in the current ANSI Standard C62.2.

Relaying Design Requirements

The interconnection relaying design requirements are intended to assure protection of the UPPCO electric system. Any additional relaying which may be necessary to protect equipment at the Project is solely the responsibility of the Project Developer to determine, design, and apply.

The relaying requirements will vary with the capacity rating of the Project, the type of generation being used, and the mode of operation (Flow-back or Non Flow-back).

All relaying proposed by the Project Developer to satisfy these requirements must be submitted for review and approved by UPPCO.

Protective Relaying General Considerations

All relays must be equipped with targets or other visible indicators to indicate that the relay has operated.

If the protective system uses AC power as the control voltage, it must be designed to disconnect the generation from the UPPCO electric system if the AC control power is lost. UPPCO will work with Project Developer for system design for this requirement.

The relay system must be designed such that the generator is prevented from energizing the UPPCO electric system if that system is de-energized.

See “Approved Relay Types” in the Generator Interconnection Supplement.

Momentary Paralleling

For situations where the Project will only be operated in parallel with the UPPCO electric system for a short duration (100 milliseconds or less), as in a make-before-break automatic transfer scheme, no additional relaying is required. Such momentary paralleling requires a modern integrated Automatic Transfer Switch (ATS) system, which is incapable of paralleling the Project with the UPPCO electric system. The ATS must be tested and verified for proper operation at least every 2 years. UPPCO may be present during this testing.

Instrument Transformer Requirements

All relaying must be connected into instrument transformers.

All current connections shall be connected into current transformers (CTs). All CTs shall be rated to provide no more than 5 amperes secondary current for all normal load conditions, and must be designed for relaying use, with an “accuracy class” of at least C50. Current transformers with an accuracy class designation such as T50 are NOT acceptable. For three-phase systems, all three phases must be equipped with CTs.

All potential connections must be connected into voltage transformers (VTs). For single-phase connections, the VTs shall be provided such that the secondary voltage does not exceed 120 volts for normal operations. For three-phase connections, the VTs shall be provided such that the line-to-line voltage does not exceed 120 volts for normal operation, and both the primary and secondary of the VTs shall be connected for grounded-wye connections.

Direct Transfer Trip (DTT)

Direct Transfer Trip is generally not required for Induction or Inverter Projects. Direct Transfer Trip generally is not required for Synchronous Projects that will operate in the Non Flow-back Mode since a simpler and more economic reverse power relay scheme can usually meet the requirements. For Synchronous Flow-back Projects, the need for DTT is determined based on the location of the PCC. UPPCO requires DTT when the total generation within a protective zone is greater than 33% of the minimum UPPCO load that could be isolated along with the generation. This prevents sustained isolated operation of the generation for conditions where generator protective relaying may not otherwise operate (see "Isolated Operation" in the Generator Interconnection Supplement).

Direct transfer trip adds to the cost and complexity of an interconnection. A DTT transmitter is required for each UPPCO protective device whose operation could result in sustained isolated operation of the generator. An associated DTT receiver at the Project is required for each DTT transmitter. A Data Circuit is required between each transmitter and receiver. Telemetry is required to monitor the status of the DTT communication.

At the Project Developer's expense, UPPCO will provide the receiver(s) that the Project Developer must install, and UPPCO will install the transmitter(s) at the appropriate UPPCO protective devices.

Reverse Power Relaying for Non Flow-back

If Flow-back Mode is not utilized, reverse power protection must be provided. The reverse power relaying will detect power flow from the Project into the UPPCO system, and operation of the reverse power relaying will separate the Project from the UPPCO system.

Automatic Reclosing

UPPCO employs automatic multiple-shot reclosing on most of the UPPCO's circuit breakers and circuit reclosers to increase the reliability of service to its customers. Automatic single-phase overhead reclosers are regularly installed on distribution circuits to isolate faulted segments of these circuits.

The Project Developer is advised to consider the effects of Automatic Reclosing (both single-phase and three-phase) to assure that the Project's internal equipment will not be damaged. In addition to the risk of damage to the Project, an out-of-phase reclosing operation may also present a hazard to UPPCO's electric system equipment since this equipment may not be rated or built to withstand this type of reclosing.

To prevent out-of-phase reclosing, circuit breakers can be modified with voltage check relays. These relays block reclosing until the parallel generation is separated and the line is "de-energized." Hydraulic single-phase overhead reclosers cannot be modified

with voltage check relays; therefore, these devices will have to be either replaced with three-phase overhead reclosers, which can be voltage controlled, or relocated beyond the Project location - depending upon the sectionalizing and protection requirements of the distribution circuit.

If the Project can be connected to more than one circuit, these revisions may be required on the alternate circuit(s) as well.

UPPCO will determine relaying and control equipment that needs to be installed to protect its own equipment from out-of-phase reclosing. Installation of this protection will be undertaken by UPPCO at the Project Developer's expense. UPPCO shall not be liable to the customer with respect to damage(s) to the Project arising as a result of Automatic Reclosing.

Single-Phase Sectionalizing

UPPCO also installs single-phase fuses and/or reclosers on its distribution circuits to increase the reliability of service to its customers. Three-phase generator installations may require replacement of fuses and/or single-phase reclosers with three-phase circuit breakers or circuit reclosers at the Project Developer's expense.

Synchronous Projects

General

If the interconnection system is certified by a nationally recognized testing laboratory to satisfy all requirements of IEEE Std. 1547, no additional equipment is required, except as noted below.

To satisfy IEEE Std. 1547 requirements for disconnection for faults, each generator must be equipped with voltage-controlled overcurrent relays. These relays shall measure and respond to currents and voltages in all three phases. Also, out-of-step relaying may be required as suggested in IEEE Std. 1547 for loss-of-synchronism conditions if the apparent voltage flicker from a loss-of-synchronism condition exceeds 5%.

If the interconnection system is not certified to satisfy requirements of IEEE Std. 1547, under/overvoltage, under/overfrequency, and voltage-controlled overcurrent relays will be required, and must conform to the requirements detailed in “Relay Setting Criteria” below. The under/overvoltage relays must monitor all three phases. All protection must use utility grade relays.

For a sample One-Line Diagram of this type of facility, see Appendix E.

Isolation Transformer and Utility Ground Fault Detection

If the Project is connected to an ungrounded distribution system, the secondary winding (UPPCO side) of the isolation transformer must be connected delta.

If the Project is connected to a grounded distribution system, the developer has a choice of the following transformer connections:

1. A grounded-wye - grounded-wye transformer connection is acceptable only if the Project's single line-to-ground fault current contribution is less than the Project's three-phase fault current contribution at the PCC,
2. The isolation transformer may be connected for a delta secondary (UPPCO side) connection with any primary (Project side) connection, or
3. Ungrounded-wye secondary connection with a delta primary connection.

If the Project is connected to a grounded distribution system via one of the isolation transformer connections specified above, ground fault detection for UPPCO faults may be required at the discretion of UPPCO, and will consist of a (59N) ground overvoltage relay or (51N) overcurrent relay. The specific application of this relay will depend on the connection of the isolation transformer:

1. If a grounded-wye - grounded-wye transformer connection is used, a time overcurrent relay must be connected into a CT located on the UPPCO side isolation transformer neutral connection.
2. If a delta secondary/grounded-wye primary connection is used, a (59N) ground overvoltage relay will be connected into the secondary of a set of three-phase VTs, which will be connected grounded-wye primary, with the secondary connected delta with one corner of the delta left open. The (59N) relay will be connected across this open-corner.
3. If an ungrounded-wye secondary/delta primary connection is used, a (59N) ground overvoltage relay will be connected into the secondary of a single VT, which will be connected from the ungrounded-wye neutral of the isolation transformer to ground.

Induction Projects

General

If the interconnection system is certified by a nationally recognized testing laboratory to satisfy all requirements of IEEE Std. 1547, no additional equipment is required.

If the interconnection system is not certified to satisfy requirements of IEEE Std. 1547, under/overvoltage, and under/overfrequency, will be required, and must conform to the requirements detailed in "Relay Setting Criteria" below. The under/overvoltage relays must monitor all three phases. All protection must use UPPCO grade relays.

For a sample One-Line Diagram of this type of facility, see Appendix F.

Isolation Transformer and UPPCO Ground Fault Detection

If the Project is connected to an ungrounded distribution system, the secondary winding (UPPCO side) of the isolation transformer must be connected delta.

If the facility is connected to a grounded distribution system, the Project Developer has a choice of the following transformer connections:

1. The isolation transformer may be connected for a delta secondary (UPPCO side) connection with any primary (Project side) connection, or
2. The isolation transformer may be connected for an ungrounded-wye secondary connection with a delta primary connection, or
3. The isolation transformer may be connected for a grounded-wye - grounded-wye connection.

If the Project is connected to a grounded distribution system via one of the isolation transformer connections specified above, ground fault detection for UPPCO faults may be required at the discretion of UPPCO. The specific application of this relay will depend on the connection of the isolation transformer:

1. If a delta secondary/grounded-wye primary connection is used, a (59N) ground overvoltage relay will be connected into the secondary of a set of three-phase VTs, which will be connected grounded-wye primary, with the secondary connected delta with one corner of the delta left open. The (59N) relay will be connected across this open-corner.

2. If an ungrounded-wye secondary/delta primary connection is used, a (59N) ground overvoltage relay will be connected into the secondary of a single VT that will be connected from the ungrounded-wye neutral of the isolation transformer to ground.
3. If a grounded-wye - grounded-wye connection is used, a time overcurrent relay must be connected into a CT located on the UPPCO side isolation transformer neutral connection.

Protection must be provided for internal faults in the isolating transformer; fuses are acceptable. In cases where it can be shown that self excitation of the induction generator cannot occur when isolated from UPPCO, UPPCO may waive the requirement that the Project Developer provide protection for UPPCO system ground faults. In all cases, ground fault detection for UPPCO faults may be required at the discretion of UPPCO.

Inverter Projects

General

If the interconnection system is certified by a nationally recognized testing laboratory to satisfy all requirements of IEEE Std. 1547, no additional equipment is required.

If the interconnection system is not certified to satisfy requirements of IEEE Std. 1547, under/overvoltage, and under/overfrequency, will be required, and must conform to the requirements detailed in "Relay Setting Criteria" below. The under/overvoltage relays must monitor all three phases. All protection must use UPPCO grade relays.

The isolation transformer (without generation on-line) must be incapable of producing ground fault current to the UPPCO system; any connection except delta primary (Project side), grounded-wye secondary (UPPCO side) is acceptable. Protection must be provided for internal faults in the isolating transformer; fuses are acceptable.

If the inverter has passed a certified anti-island test, UPPCO may waive the requirement that the Project Developer provide protection for UPPCO system ground faults. In all cases, ground fault detection for UPPCO faults may be required at the discretion of UPPCO. If required, type and methodology will be the same as Synchronous Projects listed above.

For a sample One-Line Diagram of this type of facility, see Appendix G.

Dynamometer Projects

No isolation transformer is required between the generator and the secondary distribution connection. If an isolation transformer is used for three-phase installations, any isolation transformer connection is acceptable except grounded-wye (UPPCO side), delta (Project side). Protection must be provided for internal faults in the isolating transformer; fuses are acceptable.

If an inverter is used and has passed a certified anti-island test, UPPCO may waive the requirement that the Project Developer provide protection for the UPPCO system ground faults.

General

If the interconnection system is certified by a nationally recognized testing laboratory to satisfy all requirements of IEEE Std. 1547, no additional equipment is required.

If the interconnection system is not certified to satisfy requirements of IEEE Std. 1547, under/overvoltage, and under/overfrequency, will be required, and must conform to the requirements detailed in "Relay Setting Criteria" below. The under/overvoltage relays must monitor all three phases. All protection must use UPPCO grade relays.

Additional anti-islanding schemes in conformance with IEEE Std 1547 4.4.1 may be utilized at the utilities discretion.

The isolation transformer (without generation on-line) must be incapable of producing ground fault current to the UPPCO system; any connection except delta primary (Project side), grounded-wye secondary (UPPCO side) is acceptable. Protection must be provided for internal faults in the isolating transformer; fuses are acceptable.

If an inverter is used and has passed a certified anti-island test, UPPCO may waive the requirement that the Project Developer provide protection for UPPCO system ground faults. In all cases, ground fault detection for UPPCO faults may be required at the discretion of UPPCO. If required, type and methodology will be the same as Synchronous Projects listed above.

Relay Setting Criteria

The relay settings as detailed in this section will apply in the vast majority of applications. UPPCO will issue relay settings for each individual project that will address the settings for these protective functions. All voltages will be adjusted for the specific VT ratio, and all currents will be adjusted for the specific CT ratio.

Undervoltage Relays

If an interconnection system which is certified to meet IEEE Std. 1547 is used, the undervoltage setpoints as defined in IEEE Std. 1547 will be used. Otherwise, the undervoltage relays will normally be set to trip at 88% of the nominal primary voltage at the relay location, and must reset from a trip condition if the voltage increases to 90% of the nominal primary voltage at the relay location. In order to accommodate variations in these criteria the trip point of the relays shall be adjustable over a range of 70% of the nominal voltage to 90% of the nominal voltage. The trip time shall not exceed 1.0 seconds at 90% of the relay setting.

Overvoltage Relays

If an interconnection system which is certified to meet IEEE Std. 1547 is used, the overvoltage setpoints as defined in IEEE Std. 1547 will be used. Two steps of overvoltage relaying are required. For the first overvoltage set point, the overvoltage relays will normally be set to trip at 107% of the nominal primary voltage at the relay location, and must reset from a trip condition if the voltage decreases to 105% of the nominal primary voltage at the relay location. In order to accommodate variations in these criteria the trip point of the relays shall be adjustable over a range of 105% of the nominal voltage to 120% of the nominal voltage. The trip time shall not exceed 1.0 seconds at 110% of the relay setting.

Underfrequency Relays

If an interconnection system which is certified to meet IEEE Std. 1547 is used, the underfrequency setpoints as defined in IEEE Std. 1547 will be used. Otherwise, the Underfrequency relay will normally be set for a trip point of 58.5 Hz, and must trip within 0.2 seconds. Relays with an inverse time characteristic (where the trip time changes with respect to the applied frequency) are not acceptable. These relays must respond reliably for applied source voltages as low as 70% of the nominal voltage.

Overfrequency Relays

If an interconnection system which is certified to meet IEEE Std. 1547 is used, the overfrequency setpoints as defined in IEEE Std. 1547 will be used. Otherwise, the overfrequency relay will normally be set for a trip point of 60.5 Hz, and must trip within 0.2 seconds. Relays with an inverse time characteristic are not acceptable. These relays must respond reliably for applied source voltages as low as 70% of the nominal voltage.

51V Relays – Voltage Controlled Overcurrent Relays

For synchronous generator applications, the (51V) relays must be set to detect any phase faults that may occur between the generator and the nearest three-phase fault clearing device on the UPPCO system. Since these faults may take up to 1-second to detect and isolate, the appropriate saturated direct-axis reactance of the generator will be used depending on its time constants. The settings of this device will consider the relay manufacturer's recommended practice for the type of generator and prime mover (mechanical energy source), and will be determined by UPPCO for the specific system application.

59N Relay – Ground Fault Detection

This relay will be applied to detect ground faults on the UPPCO system when the Project is connected to a grounded UPPCO system via an ungrounded transformer winding. This relay will be set for a 10% shift in the apparent power system neutral. For an ungrounded-wye transformer winding with a single 120 V secondary VT, the setting will usually be 12 Volts. For a delta transformer winding with broken delta 120 V secondary VTs, the setting will usually be 20 Volts. The time delay will normally be 1 second.

51N Relay – Ground Fault Detection

This relay will be applied to detect ground faults on the UPPCO system when the Project is connected to a grounded UPPCO system via a grounded-wye transformer winding, and will be connected into a CT in the transformer neutral connection. This relay will be set to detect faults on the directly connected UPPCO system, and the timing will be set to comply with UPPCO practice for overcurrent relay coordination. The CT ratio and specific relay setting will be determined via a fault study performed by UPPCO.

32 Relay – Reverse Power

The reverse power relay must be selected such that it can detect a power flow into the UPPCO system of a small fraction of the overall generator capacity. The relay will normally be set near its minimum (most sensitive) setting, and will trip after a 1 second time delay. The delay will avoid unnecessary tripping for momentary conditions.

Maintenance and Testing

UPPCO reserves the right to test the relaying and control equipment that involves protection of the UPPCO electric system whenever UPPCO determines a reasonable need for such testing exists.

The Project Developer is solely responsible for conducting proper periodic maintenance on the generating equipment and its associated control, protective equipment, interrupting devices, and main Isolation Device, per manufacturer recommendations.

The Project Developer is responsible for the periodic scheduled maintenance on those relays, interrupting devices, control schemes, and batteries that involve the protection of the UPPCO electric system. If the interconnection system is certified to meet IEEE Std. 1547, the

Standard requires that testing be conducted in accordance with written test procedures, and the nationally recognized testing laboratory providing certification, will require that such test procedures be available before certification of the equipment. Otherwise, a periodic maintenance program is to be established to test these relays at least every 2 years. Test reports of such testing shall be maintained by the Project Developer and made available for UPPCO inspection upon request for a period of four years.

Each routine maintenance check of the relaying equipment shall include both an exact calibration check and an actual trip of the circuit breaker or contactor from the device being tested. For each test, a report shall be submitted to UPPCO indicating the results of the tests made and the "as found" and "as left" relay calibration values. Visually setting, without verification, a calibration dial or tap is not considered an adequate relay calibration check.

Installation and Design Approval

The Project Developer must provide UPPCO with 10 business days advance written notice of when the Project will be ready for inspection, testing, and approval.

UPPCO may review the design drawings for approval, after the Engineering Review has been completed. The design drawings must be submitted by the Project Developer in accordance with "Engineering Design Drawing Requirements" (see Generator Interconnection Supplement). If reviewed, UPPCO shall either approve the Project Developer's design drawings as submitted or return them to the Project Developer with a clear statement as to why they were not approved. Where appropriate, UPPCO will indicate required changes on the engineering drawings.

In the event that revisions are necessary to the Project Developer's submitted design drawings, and the Project Developer submits revised design drawings to UPPCO, UPPCO shall either approve, in writing, the Project Developer's revised design drawings as resubmitted, or return them to the Project Developer with a clear statement as to why they were not approved. Where appropriate, UPPCO will indicate required changes on the engineering drawings.

UPPCO will retain one copy of the approved design drawings.

In the event that UPPCO exercises its option to Acceptance Test the proposed interconnection relays that protect the UPPCO electric system, then UPPCO shall communicate the results of that testing to the Project Developer for both the relays and the necessary documentation on the relays.

Prior to final approval for Parallel Operation, UPPCO's specified relay calibration settings shall be applied and a commissioning test must be performed on the generator relaying and control equipment that involves the protection of the UPPCO electric system. The commissioning test must be witnessed by UPPCO and can be performed by UPPCO at the Project Developer's request. Upon satisfactory completion of this test and final inspection, UPPCO will provide written permission for Parallel Operation. If the results are unsatisfactory, UPPCO will provide written communication of these results and required action to the Project Developer.

In the event the Project Developer proposes a revision to UPPCO's approved relaying and control equipment used to protect the UPPCO electric system and submits a description and engineering design drawings of the proposed changes, UPPCO shall either approve the Project Developer's amended design drawings or return them to the Project Developer with a clear statement as to why they were not approved. Where appropriate, UPPCO will indicate required changes on the engineering drawings.

Telemetry and Disturbance Monitoring Requirements

If DTT is required, telemetry to monitor the DTT is also required. Disturbance monitoring is also recommended as being beneficial to the Project Developer and UPPCO, but is not required in all cases.

Telemetry enables UPPCO to operate the electric system safely and reliably under both normal and emergency conditions. UPPCO measures its internal load plus losses (generation) on a real-time basis via an extensive telemetry system. This system sums all energy flowing into the UPPCO electric system from Projects interconnected to the system and from interconnections with other utilities. During system disturbances when portions of the electrical systems are out of service, it is essential to know if a generator is on line or off line to determine the proper action to correct the problem. Time saved during restoration activities translates to fewer outages and outages of shorter duration for UPPCO's customers.

UPPCO evaluates the performance of the overall protective system for all faults on the electric system. It is critical that sufficient monitoring of the protective system is in place to determine its response. It is preferable to deploy disturbance monitoring into all Projects, but it can be expensive to deploy. Therefore, disturbance monitoring is required only for installations at UPPCO's discretion.

The Project Developer shall provide a suitable indoor location, approved by UPPCO, for UPPCO's owned, operated, and maintained Remote Terminal Unit (RTU). The location must be equipped with a 48 V or 125 V DC power supply. The Project Developer must provide the necessary phone (or alternate) and data circuits, and install a telephone (or alternate) backboard for connections to the UPPCO RTU and metering equipment. All phone circuits must be properly protected as detailed in IEEE Std. 487. See "Typical Meter and RTU Installation Where Telemetry is Required" in the Generator Interconnection Supplement.

When telemetry is required, the following values will be telemetered:

1. Real and reactive power flow at the PCC.
2. Voltage at the PCC.
3. The status (normal/fail) of protective relay Communication Channels. A status indication of "FAIL" indicates the Communication Channel used for relaying (i.e. transfer trip) is unable to perform its protective function. This includes the following individual contacts from each individual Direct Transfer Trip receiver which is required by UPPCO:

- i. Loss-of-guard (LOG) alarm
 - ii. Receive-trip relay (RTX)
 - iii. Lockout relay
4. The status (open/closed) of the main isolating breaker and each generating unit breaker (if the Project is composed of multiple units, a single logical (OR) status of the individual generator breaker states, indicating all generator breakers are open or any one or more generator breakers are closed, is permissible). A closed status would be indicated if any individual generator is on line.

For disturbance monitoring, the RTU will be equipped with “sequence of events” recording.

The Project Developer shall, at a minimum, provide, wired to a terminal block near the RTU panel, sufficient connections to separately monitor the status of the three items listed above in item 3. Monitoring of the items listed below is optional, but is highly recommended since this will allow UPPCO to more quickly analyze abnormal events which might involve the Project and this additional monitoring should be able to be accomplished at minimum incremental cost:

1. An output contact of an instantaneous relay to act as a ground fault detector for faults on the UPPCO electric system. This relay shall be connected into the same sensing source as the ground fault protective relay required by UPPCO.
2. Each and every trip of an interconnection isolation device, which is initiated by any of the generator interconnection relaying schemes required by UPPCO.
3. Each and every trip of an interconnection isolation device, which is initiated by any of the protective systems for the generator.
4. Each and every trip or opening of an interconnecting isolation device, which is initiated by any other manual or electrical means.
5. A contact indicating the position of the Project’s primary-side main breaker.
6. A contact indicating operation of the over/undervoltage relays.
7. A contact indicating operation of the under/over frequency relay or UPPCO’s ground fault relay.
8. A contact indicating operation of the Project provided transformer bank relaying.
9. A contact indicating operation of any of the (51V) relaying.
10. A contact indicating the position of the high-side fault-clearing device.
11. A contact indicating the position of the reverse power relay, if said relay is required by UPPCO.

If any of the functions indicated in items 2-4, 6, 7, 9, or 11 are combined into a multi-functional device, either (1) each of those functions should be monitored independently on the RTU, or (2) provisions acceptable to UPPCO should be provided to interrogate the multi-functional device such that the operation of the individual functions may be evaluated separately.

Telemetry, when required, will be provided by UPPCO at the Project Developer's expense. In addition to other telemetry costs, a one-time charge will be assessed to the Project Developer for equipment and software installed at UPPCO's System Control Center to process the data signals.

Miscellaneous Operational Requirements

Miscellaneous requirements include synchronizing equipment for Parallel Operation, reactive requirements, standby power considerations, and system stability limitations.

Operating in Parallel

The Project Developer will be solely responsible for the required synchronizing equipment and for properly synchronizing the Project with the UPPCO electric system.

Voltage fluctuation at the PCC during synchronizing shall be limited per IEEE std. 1547.

The Project Developer will notify UPPCO prior to synchronizing to and prior to scheduled disconnection from the electric system.

These requirements are directly concerned with the actual operation of the Project with UPPCO:

- The Project may not commence parallel operation until approval has been given by UPPCO. The completed installation is subject to inspection by UPPCO prior to approval. Preceding this inspection, all contractual agreements must be executed by the Project Developer.
- The Project must be designed to prevent the Project from energizing into a de-energized UPPCO line. The Project's circuit breaker or contactor must be blocked from closing in on a de-energized circuit.
- The Project shall discontinue parallel operation with a particular service and perform necessary switching when requested by UPPCO for any of the following reasons:
 1. When public safety is being jeopardized.
 2. During voltage or loading problems, system emergencies, or when abnormal sectionalizing or circuit configuration occurs on the UPPCO system.

3. During scheduled shutdowns of UPPCO equipment that are necessary to facilitate maintenance or repairs. Such scheduled shutdowns shall be coordinated with the Project.
4. In the event there is demonstrated electrical interference (i.e. Voltage Flicker, Harmonic Distortion, etc.) to UPPCO's customers, suspected to be caused by the Project, and such interference exceeds then current system standards, UPPCO reserves the right, at UPPCO's initial expense, to install special test equipment as may be required to perform a disturbance analysis and monitor the operation and control of the Project to evaluate the quality of power produced by the Project. In the event that no standards exist, then the applicable tariffs and rules governing electric service shall apply. If the Project is proven to be the source of the interference, and that interference exceeds UPPCO's standards or the generally accepted industry standards, then it shall be the responsibility of the Project Developer to eliminate the interference problem and to reimburse UPPCO for the costs of the disturbance monitoring installation, removal, and analysis, excluding the cost of the meters or other special test equipment.
5. When either the Project or its associated synchronizing and protective equipment is demonstrated by UPPCO to be improperly maintained, so as to present a hazard to the UPPCO system or its customers.
6. Whenever the Project is operating isolated with other UPPCO customers, for whatever reason.
7. Whenever a loss of communication channel alarm is received from a location where a communication channel has been installed for the protection of the UPPCO system.
8. Whenever UPPCO notifies the Project Developer in writing of a claimed non-safety related violation of the Interconnection Agreement and the Project Developer fails to remedy the claimed violation within ten working days of notification, unless within that time either the Project Developer files a complaint with the MPSC seeking resolution of the dispute or the Project Developer and UPPCO agree in writing to a different procedure.

If the Project has shown an unsatisfactory response to requests to separate the generation from the UPPCO system, UPPCO reserves the right to disconnect the Project from parallel operation with the UPPCO electric system until all operational issues are satisfactorily resolved.

Reactive Power Control

Synchronous generators that will operate in the Flow-back Mode must be dynamically capable of providing 0.90 power factor lagging (delivering reactive power to UPPCO) and 0.95 power factor leading (absorbing reactive power from UPPCO) at the Point of Receipt. The Point of Receipt is the location where UPPCO accepts delivery of the output of the Project. The Point of Receipt can be the physical location of the billing meters or a location where the billing meters are not located, but adjusted for line and transformation losses.

Induction and Inverter Projects that will operate in the Flow-back Mode must provide for their own reactive needs (steady state unity power factor at the Point of Receipt). To obtain unity power factor, the Induction or Inverter Project can:

1. Install a switchable VAR supply source to maintain unity power factor at the Point of Receipt; or
2. Provide UPPCO with funds to install a VAR supply source equivalent to that required for the Project to attain unity power factor at the Point of Receipt at full output.

There are no interconnection reactive power capability requirements for Synchronous, Induction, and Inverter Projects that will operate in the Non Flow-back Mode. UPPCO's existing rate schedules, incorporated herein by reference, contain power factor adjustments based on the power factor of the metered load at these facilities.

Standby Power

Standby power will be provided under the terms of an approved rate set forth in UPPCO's Standard Rules and Regulations. The Project Developer should be aware that to qualify for Standby Rates, a separate meter must be installed at the generator.

If outside of UPPCO's franchise area, it will be the Project Developer's responsibility to arrange contractually and technically for the supply of its facility's standby, maintenance, and any supplemental power needs.

System Stability and Site Limitations

The Stiffness Ratio is the combined three-phase short circuit capability of the Project and UPPCO divided by the short circuit capability of the Project measured at the PCC. A stability study may be required for Projects with a Stiffness Ratio of less than 40. Five times the generator rated kVA will be used as a proxy for short circuit current contribution for induction generators. For synchronous Projects, with a Stiffness Ratio of less than 40, UPPCO requires special generator trip schemes or loss of synchronism (out-of-step) relay protection. If the apparent voltage flicker from a loss-of-synchronism condition exceeds 5%, an out-of-step relay will be required. This type of protection is typically applied at the PCC and trips the entire Project off-line, if instability is detected, to protect the UPPCO electric system and its customers. If the Project Developer chooses not to provide for mitigation of unacceptable voltage flicker (above five percent), UPPCO may disallow the interconnection of the Project or require a new dedicated interconnection at the Project Developer's expense.

The Project Developer is responsible for evaluating the consequences of unstable generator operation or voltage transients on Project equipment and determining, designing, and applying any relaying which may be necessary to protect that equipment. This type of protection is typically applied on individual generators to protect the Project facilities.

UPPCO will determine if operation of the Project will create objectionable voltage flicker and/or disturbances to other UPPCO customers and develop any required mitigation measures at the Project Developer's expense.

Revenue Metering Requirements

UPPCO will own, operate, and maintain all required billing metering equipment at the Project Developer's expense.

Non Flow-back Projects

An UPPCO meter will be installed that only records power flow energy deliveries to the Project.

Flow-back Projects

Special billing metering may be required. The Project Developer may be required to provide, at no cost to UPPCO, a dedicated communication circuit, to allow remote access to the billing meter by UPPCO. This circuit shall be terminated within ten feet of the meter involved. Ground fault protection for this circuit may be required, and coordination with the telephone company and all associated costs will be by Project Developer.

The Project Developer shall provide UPPCO access to the premises at all times to install, turn on, disconnect, inspect, test, read, repair, or remove the metering equipment. The Project Developer may, at its option, have a representative witness this work.

The metering installations shall be constructed in accordance with the practices, which normally apply to the construction of metering installations for residential, commercial, or industrial customers. At a minimum three meters will be required; two at the PCC, one import and one export and one at the generator. For Projects with multiple generators, metering of each generator may be required. When practical, multiple generators may be metered at a common point provided the metered quantity represents only the gross generator output.

UPPCO shall supply to the Project Developer all required metering equipment and the standard detailed specifications and requirements relating to the location, construction, and access of the metering installation and will provide consultation pertaining to the meter installation as required. UPPCO will endeavor to coordinate the delivery of these materials with the Project Developer's installation schedule during normal scheduled business hours.

The Project Developer may be required to provide a mounting surface for the metering equipment, including enclosures and conduit. The mounting surface and location must meet UPPCO's specifications and requirements.

The responsibility for installation of the equipment is shared between UPPCO and the Project Developer. The Project Developer may be required to install some of the metering equipment on its side of the PCC, including instrument transformers, cabinets, conduits, and mounting surfaces. UPPCO shall install the meters and communication links. UPPCO will endeavor to

coordinate the installation of these items with the Project Developer's schedule during normal scheduled business hours.

Communication Circuits

The Project Developer is responsible for ordering and acquiring the telephone circuit required for the Project Interconnection. The Project Developer will assume all installation, operating, and maintenance costs associated with the telephone circuits, including the monthly charges for the telephone lines and any rental equipment required by the local telephone provider. However, at UPPCO's discretion, UPPCO may select an alternative communication method, such as wireless communications. Regardless of the method, the Project Developer will be responsible for all costs associated with the material, installation and maintenance, whereas UPPCO will be responsible to define the specific communication requirements.

UPPCO will cooperate and provide UPPCO information necessary for proper installation of the telephone (or alternate) circuits upon written request.

A dedicated communication circuit is required for access to the billing meter by UPPCO. When DTT is required, a modular RJ-11 jack must also be installed within six feet of the billing metering equipment, to allow UPPCO to use this circuit for voice communication with personnel performing master station checkout of the RTU. This dial-up voice-grade circuit shall be a local telephone company provided business measured line without dial-in or dial-out call restrictions.

If DTT is required, a separate dedicated 4-wire, Class A, Data Circuit must be installed and protected as specified by the local telephone UPPCO for each DTT receiver and for the RTU. The circuit must be installed in rigid metallic conduit from the RTU and each DTT receiver to the point of connection to the telephone Utility equipment. Wall space must be provided for adjacent mounting next to the telephone board, of the billing metering panel and a telemetry enclosure. The billing metering panel is typically 60 inches high by 48 inches wide and the telemetry enclosure is typically 24 inches high by 24 inches wide. A clear space of 4.5 feet in front of this equipment is required to permit maintenance and testing. A review of each installation shall be made to determine the location and space requirements most agreeable to UPPCO and the Project Developer.

Appendix A

Interconnection Process Flow Diagram

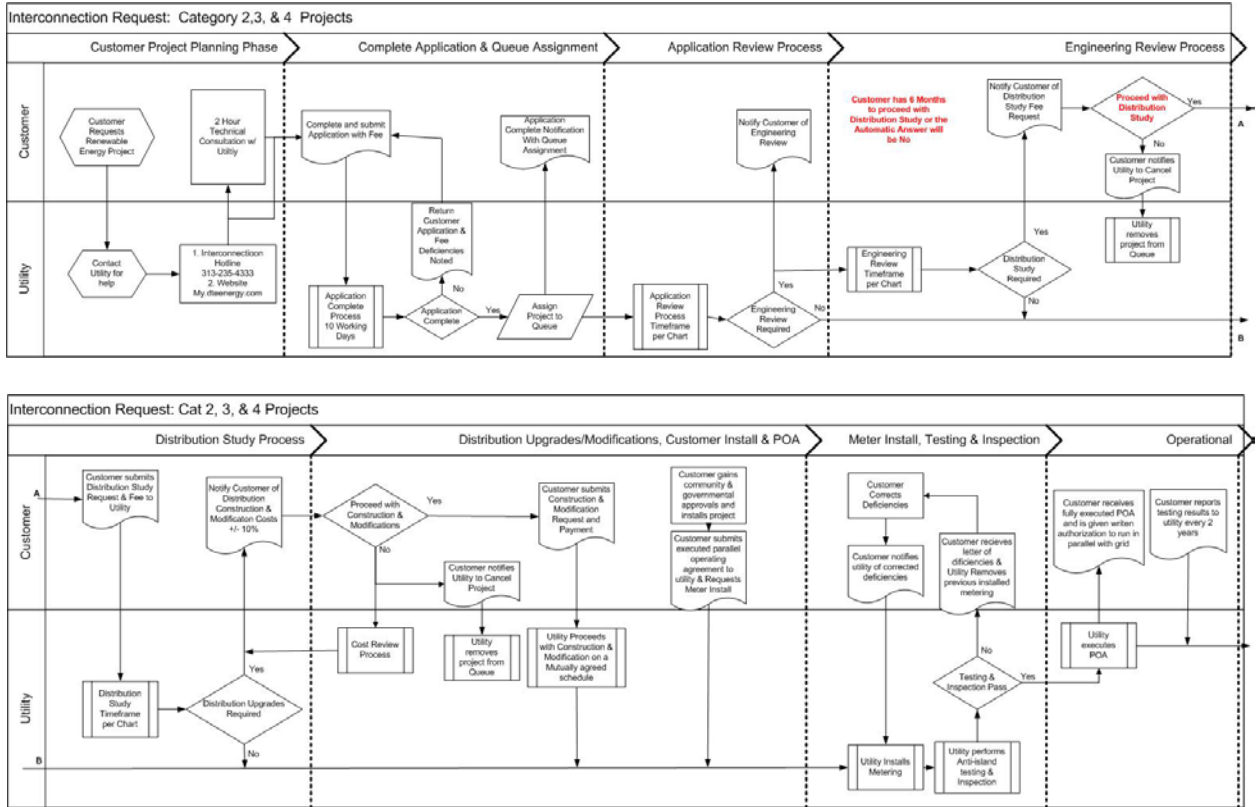

Appendix B

Interconnection Table – Applicant Costs

	Application Review	Engineering Review	Distribution Study	Distribution Upgrades	Testing & Inspection
Category 3	\$150	\$0	Propose fixed Fee	Actual or Max Approved by Commission	Actual or Max Approved by Commission

* Costs incurred by affected systems are born directly by the applicant and are not included in the table.

** Projects greater than 6MW will have an initial fixed fee with actual cost true up at the completion of the study.

Combined Net Metering / Interconnection Table - Applicant Costs

	Net Meter Program Fee	Application Review	Engineering Review	Distribution Study	Distribution Upgrades	Testing & Inspection
Category 3 Methane Digester Only	\$25	\$75	\$0	Propose fixed fee	Actual or Max Approved by Commission	\$0

Interconnection Timeline – Working Days

	Application Complete	Application Review	Engineering Study Completion	Distribution Study Completion	Distribution Upgrades	Testing & Inspection
Category 3	10 days	10 days	15 days	15 days	Mutually Agreed	10 days to notify of scheduled visit

Appendix C

Procedure Definitions

Alternative electric supplier (AES): as defined in section 10g of 2000 PA 141, MCL 460.10g

Alternative electric supplier net metering program plan: document supplied by an AES that provides detailed information to an applicant about the AES's net metering program.

Applicant: Legally responsible person applying to an electric utility to interconnect a project with the electric utility's distribution system or a person applying for a net metering program. An applicant shall be a customer of an electric utility and may be a customer or an AES.

Application Review: Review by the electric utility of the completed application for interconnection to determine if an engineering review is required.

Area Network: A location on the distribution system served by multiple transformers interconnected in an electrical network circuit.

Category 1: An inverter based project of 20kW or less that uses equipment certified by a nationally recognized testing laboratory to IEEE 1547.1 testing standards and in compliance with UL 1741 scope 1.1A.

Category 2: A project of greater than 20 kW and not more than 150 kW.

Category 3: A project of greater than 150 kW and not more than 550 kW.

Category 4: A project of greater than 550 kW and not more than 2 MW.

Category 5: A project of greater than 2 MW.

Certified equipment: A generating, control, or protective system that has been certified as meeting acceptable safety and reliability standards by a nationally recognized testing laboratory in conformance with UL 1741.

Commission: The Michigan Public Service Commission

Commissioning test: The procedure, performed in compliance with IEEE 1547.1, for documenting and verifying the performance of a project to confirm that the project operates in conformity with its design specifications.

Customer: A person who receives electric service from an electric utility's distribution system or a person who participates in a net metering program through an AES or electric utility.

Customer-generator: A person that uses a project on-site that is interconnected to an electric utility distribution system.

Distribution system: The structures, equipment, and facilities operated by an electric utility to deliver electricity to end users, not including transmission facilities that are subject to the jurisdiction of the federal energy regulatory commission.

Distribution system study: A study to determine if a distribution system upgrade is needed to accommodate the proposed project and to determine the cost of an upgrade if required.

Electric provider: Any person or entity whose rates are regulated by the commission for selling electricity to retail customers in the state.

Electric utility: Term as defined in section 2 of 1995 PA 30, MCL 460.562.

Eligible electric generator: A methane digester or renewable energy system with a generation capacity limited to the customer's electrical need and that does not exceed the following:

- 150 kW of aggregate generation at a single site for a renewable energy system
- 550 kW of aggregate generation at a single site for a methane digester

Engineering Review: A study to determine the suitability of the interconnection equipment including any safety and reliability complications arising from equipment saturation, multiple technologies, and proximity to synchronous motor loads.

Full retail rate: The power supply and distribution components of the cost of electric service. Full retail rate does not include system access charge, service charge, or other charge that is assessed on a per meter basis.

IEEE: Institute of Electrical and Electronics Engineers

IEEE 1547: IEEE "Standard for Interconnecting Distributed Resources with Electric Power Systems"

IEEE 1547.1: IEEE "Standard Conformance Test Procedures for Equipment Interconnecting Distributed Resources with Electric Power Systems"

Interconnection: The process undertaken by an electric utility to construct the electrical facilities necessary to connect a project with a distribution system so that parallel operation can occur.

Interconnection procedures: The requirements that govern project interconnection adopted by each electric utility and approved by the commission.

kW: kilowatt

kWh: kilowatt-hours

Material modification: A modification that changes the maximum electrical output of a project or changes the interconnection equipment including the following:

- Changing from certified to non-certified equipment
- Replacing a component with a component of different functionality or UL listing.

Methane digester: A renewable energy system that uses animal or agricultural waste to produce fuel gas that can be burned for the generation of electricity or steam.

Modified net metering: A utility billing method that applies the power supply component of the full retail rate to the net of the bidirectional flow of kWh across the customer interconnection with the UPPCO distribution system during a billing period or time-of-use pricing period.

MW: megawatt

Nationally recognized testing laboratory: Any testing laboratory recognized by the accreditation program of the U.S. department of labor occupational safety and health administration.

Parallel operation: The operation, for longer than 100 milliseconds, of a project while connected to the energized distribution system.

Project: Electrical generating equipment and associated facilities that are not owned or operated by an electric utility.

Renewable energy credit (REC): A credit granted pursuant to the commission's renewable energy credit certification and tracking program in section 41 of 2008 PA 295, MCL 460.1041.

Renewable energy resource: Term as defined in section 11(i) of 2008 PA 295, MCL 460.1011(i)

Renewable energy system: Term as defined in section 11(k) of 2008 PA 295, MCL 460.1011(k).

Spot network: A location on the distribution system that uses 2 or more inter-tied transformers to supply an electrical network circuit.

True net metering: A utility billing method that applies the full retail rate to the net of the bidirectional flow of kW hours across the customer interconnection with the UPPCO distribution system, during a billing period or time-of-use pricing period.

UL: Underwriters Laboratory

UL 1741: The "Standard for Inverters, Converters, Controllers and Interconnection System Equipment for Use with Distributed Energy Resources."

UL 1741 scope 1.1A: Paragraph 1.1A contained in chapter 1, section 1 of UL 1741.

Uniform interconnection application form: The standard application forms, approved by the commission under R 460.615 and used for category 1, category 2, category 3, category 4, and category 5 projects.

Uniform interconnection agreement: The standard interconnection agreements approved by the commission under R 460.615 and used for category 1, category 2, category 3, category 4, and category 5 projects.

Uniform net metering application: The net metering application form approved by the commission under R 460.642 and used by all electric utilities and AES.

Working days: Days excluding Saturdays, Sundays, and other days when the offices of the electric utility are not open to the public

Appendix D

Site Plan

SITE PLAN

APPLICANT	
ADDRESS	
CITY/TOWN	SIGNATURE

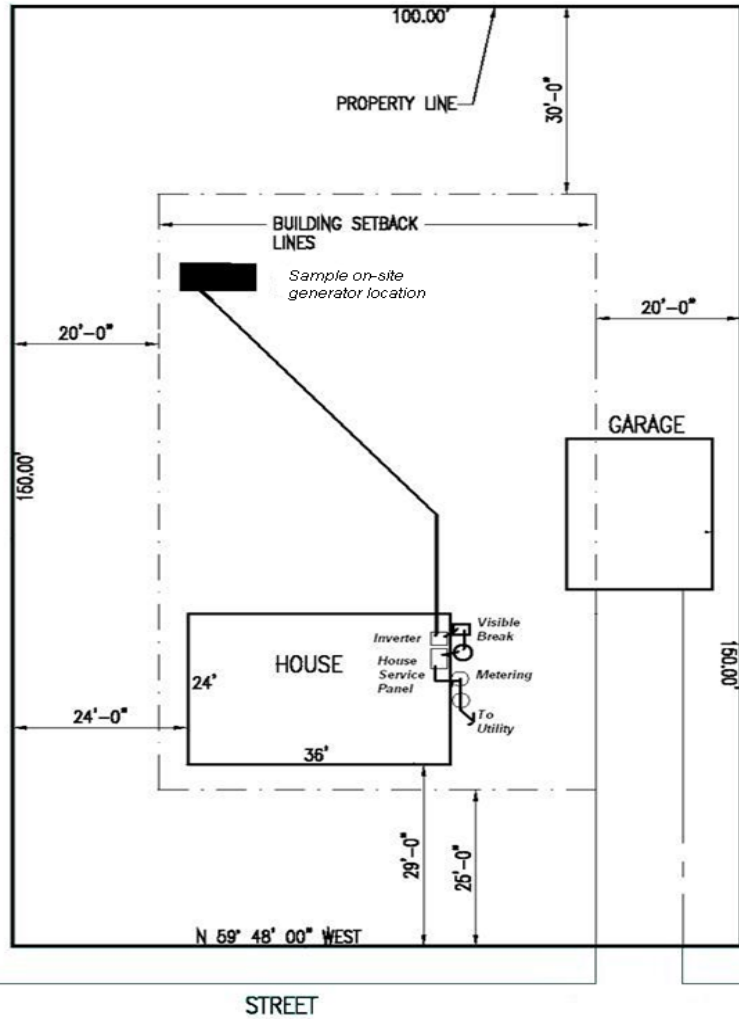

Appendix E

Sample Synchronous One-Line

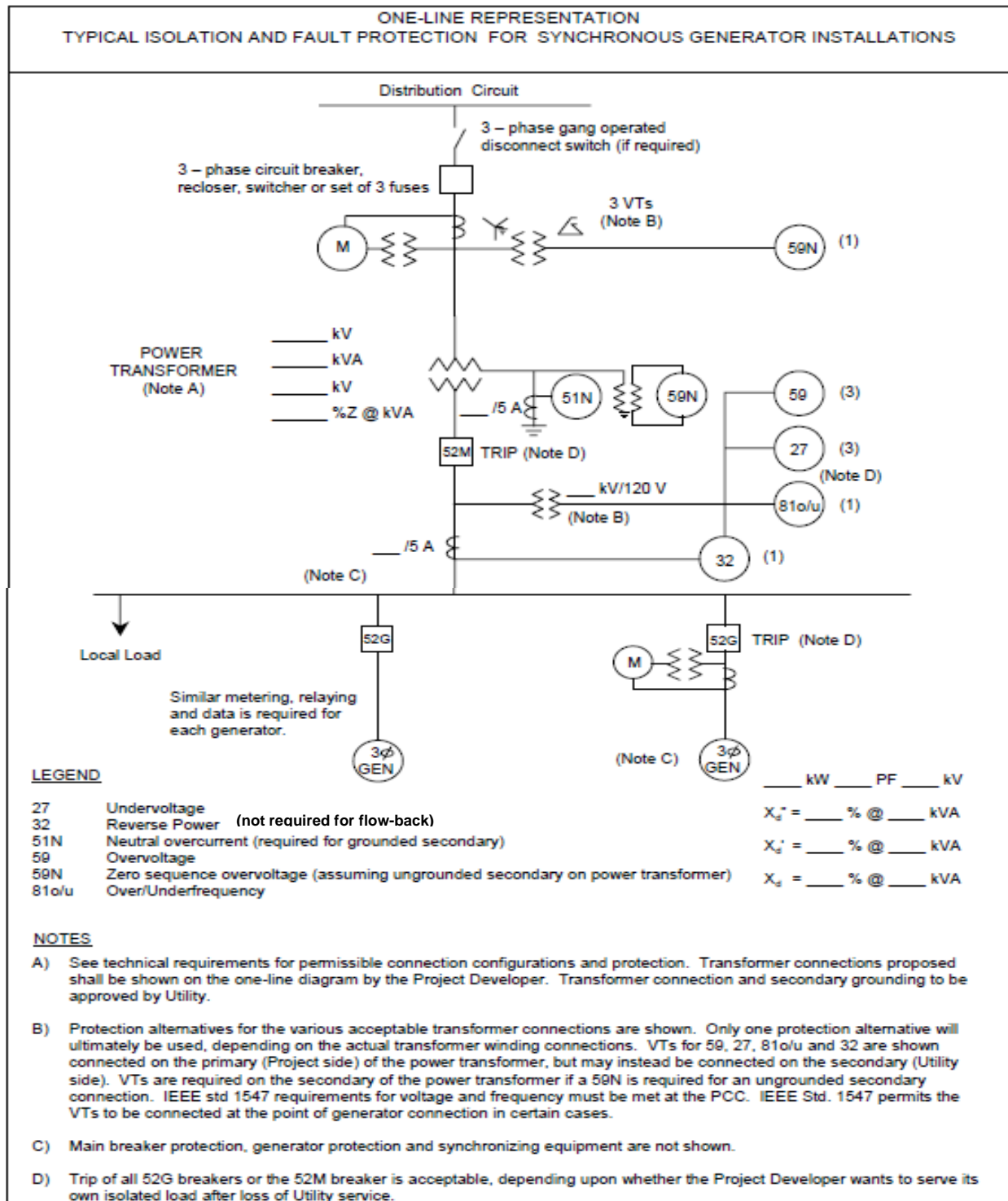

Instructions: Attach data sheets as required. Indicate in the table below the page number of the attached data (manufacturer's data where appropriate) on which the requested information is provided. Provide one table for each unique generator.

Synchronous Electric Generator(s) at the Project

Generator No _____

Item No	Data Value	Data Description	Attached Page No
1		Generator Type (synchronous or induction)	
2		Generator Nameplate Voltage	
3		Generator Nameplate Watts or Volt-Amperes	
4		Generator Nameplate Power Factor (pf)	
5		Direct axis reactance (saturated)	
6		Direct axis transient reactance (saturated)	
7		Direct axis sub-transient reactance (saturated)	
8		Short Circuit Current contribution from generator at the Point of Common Coupling (single-phase and three-phase)	
9		National Recognized Testing Laboratory Certification	
10		Written Commissioning Test Procedure	

Appendix F

Sample Induction One-Line

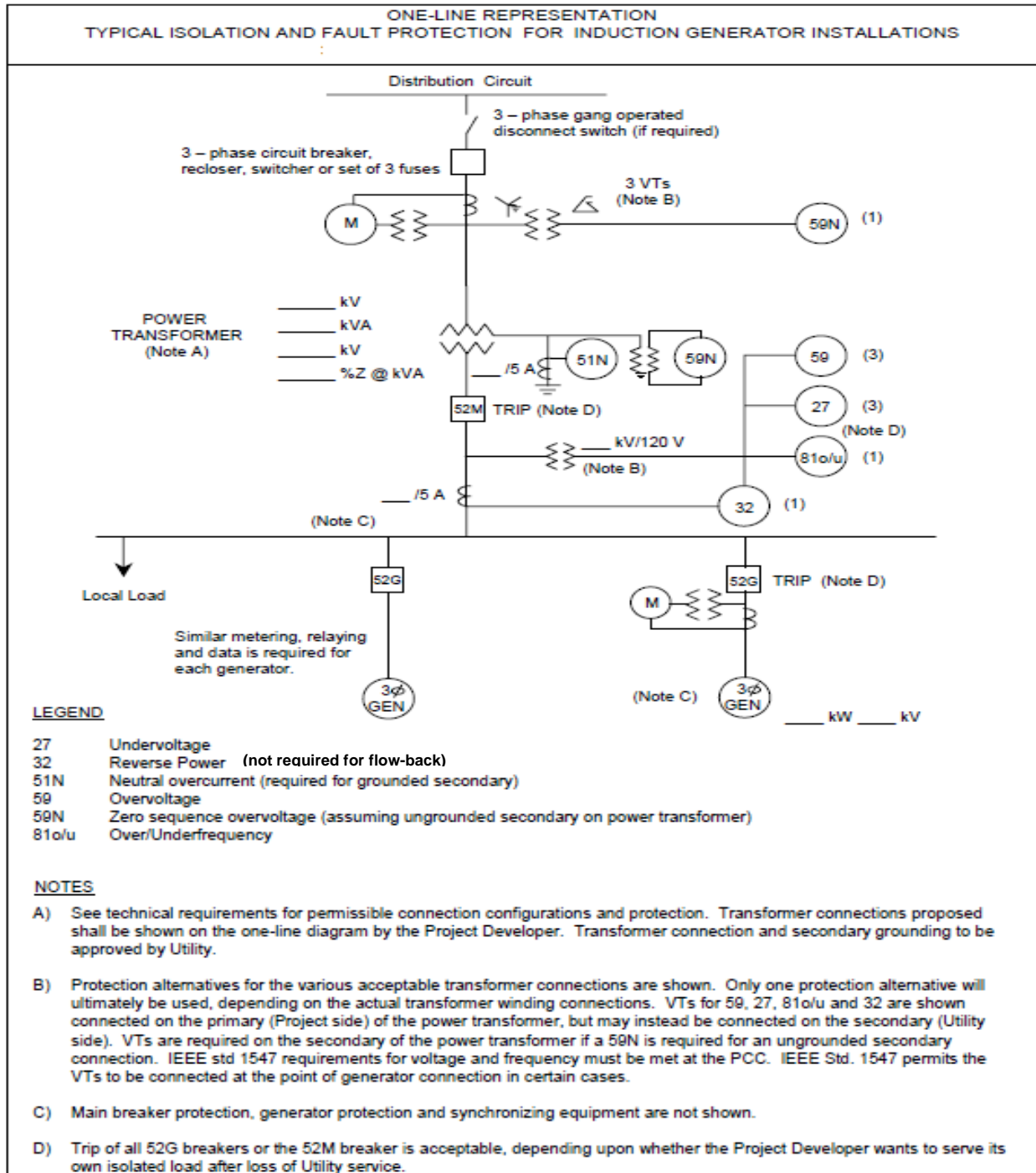

Instructions: Attach data sheets as required. Indicate in the table below the page number of the attached data (manufacturer's data where appropriate) on which the requested information is provided. Provide one table for each unique generator.

Induction Electric Generator(s) at the Project: Generator No _____

Item No	Data Description	Attached Page No
1	Generator Type (Inverter)	
2	Generator Nameplate Voltage	
3	Generator Nameplate Watts or Volt-Amperes	
4	Generator Nameplate Power Factor (pf)	
5	Short Circuit Current contribution from generator at the Point of Common Coupling (single-phase and three-phase)	
6	National Recognized Testing Laboratory Certification	
7	Written Commissioning Test Procedure	

Appendix G Sample One-Line Inverter

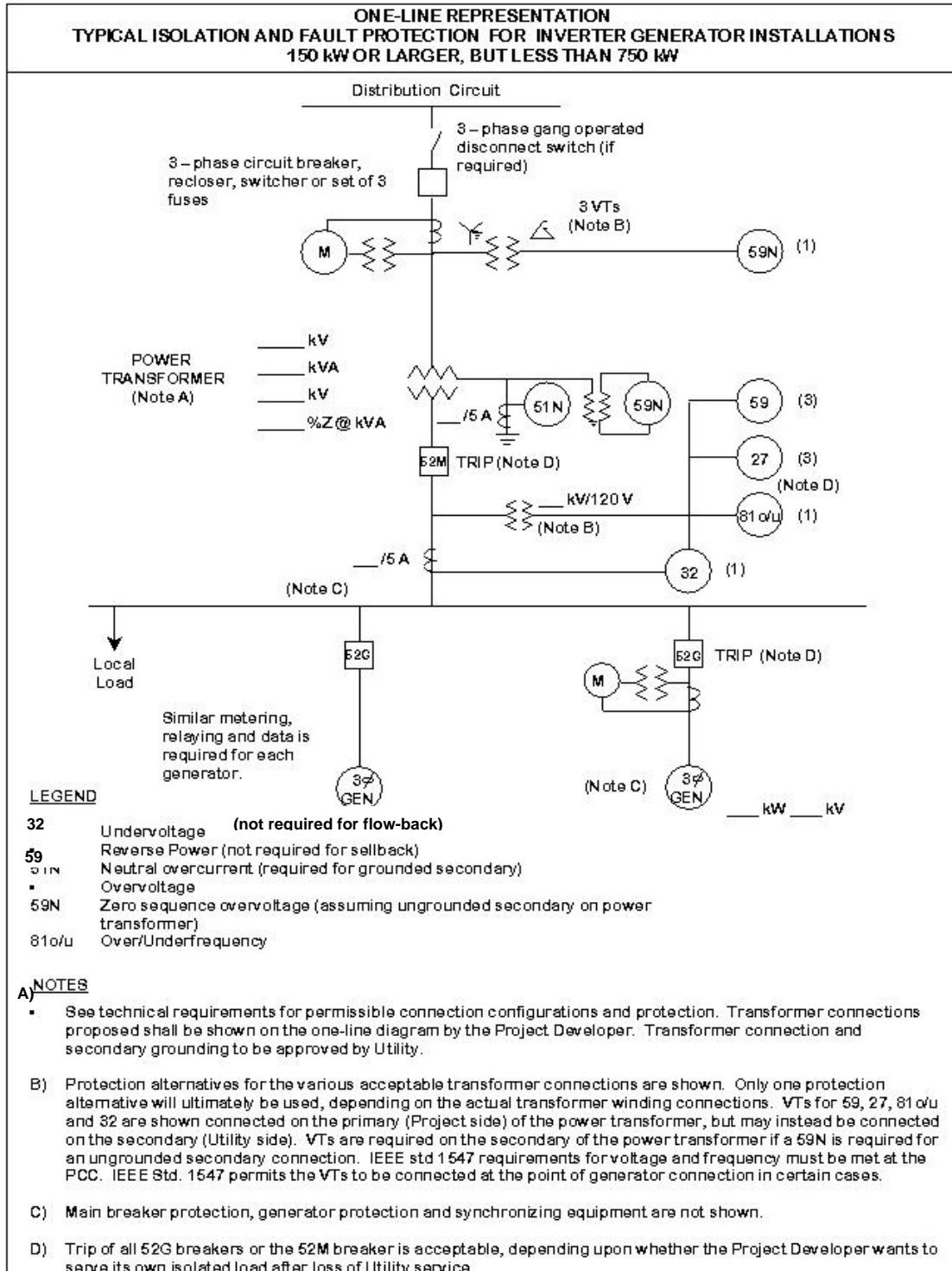

Appendix H

Sample One Line Diagram for Non-Flow Back projects

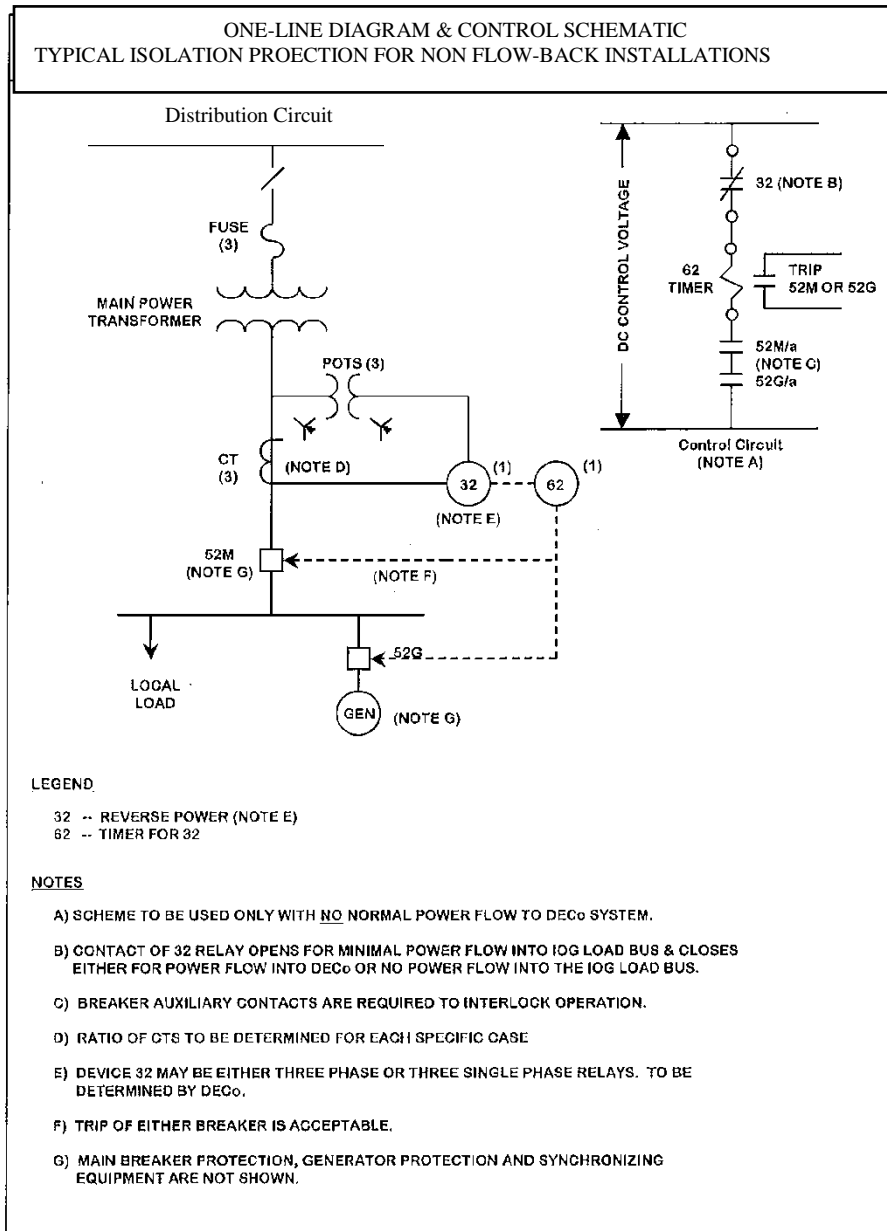

Appendix I

Sample One Line Diagram for Flow-Back projects

