

**Section 4 – Single-Phase Metering**

<b>4-1</b>	<b>Overhead Service Requirements.....</b>	<b>2</b>
4-1.1	<i>Overhead 100-200 Amp - Option 1 .....</i>	<i>3</i>
4-1.2	<i>Overhead 100-200 Amp - Option 2 .....</i>	<i>4</i>
4-1.3	<i>Overhead 320 Amp .....</i>	<i>5</i>
<b>4-2</b>	<b>Underground Service Requirements .....</b>	<b>6</b>
4-2.1	<i>Underground 200 Amp - Pedestal - Standard.....</i>	<i>7</i>
4-2.2	<i>Underground 320 Amp.....</i>	<i>8</i>
<b>4-3</b>	<b>Services 400-800 Amp – CT Metering .....</b>	<b>9</b>
<b>4-4</b>	<b>Overhead Service - Meter Poles/Posts.....</b>	<b>10</b>
<b>4-5</b>	<b>Mobile Home Services.....</b>	<b>11</b>
<b>4-6</b>	<b>Temporary Services/Construction Power.....</b>	<b>12</b>
<b>4-7</b>	<b>120/208 Volt Service (100-200 Amp).....</b>	<b>15</b>

## 4-1 Overhead Service Requirements

See Section 3-2 for General Metering Requirements

1. For 100 & 200A services, service entrance cable (rather than conduit) is acceptable if installed properly, accepted by local inspection authority, and not placed behind any siding.
2. Service entrance cable and/or conduit shall be adequately supported with clamps. The meter socket shall also be adequately attached to the structure.
3. Supports used to support service-drop conductors to attain clearance over buildings are not allowed for new installations. For existing installations, they must be substantial and meet the requirements of NEC 230.29.
4. The weather head must extend at least 6 inches above the "attachment point" for the service drop. This "attachment point" must be installed by the customer. It must be adequately attached so it can handle 650 lbs. of line tension.
5. The conductor coming out of the weather head shall be at least 18 inches long. The Company will make the connections to the overhead service conductors.
6. The meter socket shall be installed 4-6 ft above ground and be readily accessible to be read, tested, and inspected.
7. Company employees must designate the service location and specify the mounting height of the periscope due to code clearance issues with the overhead service drop conductors.
8. All periscopes (unsupported conduit extending above the roof) shall be made of rigid metal electrical conduit and shall be back guyed above 36" (per NEC 230.28). Aluminum, IMC or thin wall are NOT acceptable. Minimum size shall be 2 inch for 0-200 amp, because of strength requirements. This includes upgrades to 100 Amps. No couplings can be above where the conduit enters the roof overhang or anywhere above the roof on the periscope.
9. Communication and customer-owned circuits cannot be attached to electrical entrance periscopes (NEC 230.28) but can be grandfathered if attached prior to 1996.
10. The drip loop and overhead service conductors shall not be readily accessible and shall not be located within 3 feet in any direction from windows (designed to open), doors, porches or similar structures (per NEC 230.9(A)). An exception is above the top level of a window.
11. If an overhead service is mounted on a pole or post, the pole or post shall be back guyed, having a minimum of a 6-inch dia. top, and be pressure-treated with a wood preservative. An alternative is a minimum 6" x 6" treated timber. This pole or post location, height, and burial depth shall be approved by the Company.

4-1.1 Overhead 100-200 Amp - Option 1

Specifications:

- Ringless Type Meter Socket
- Outdoor Enclosure (Nema type 3R)
- 1 Phase, 3-Wire
- 4 Jaw Meter Socket
- Horn Bypass
- Sealable
- No cover over meter
- UL Listed

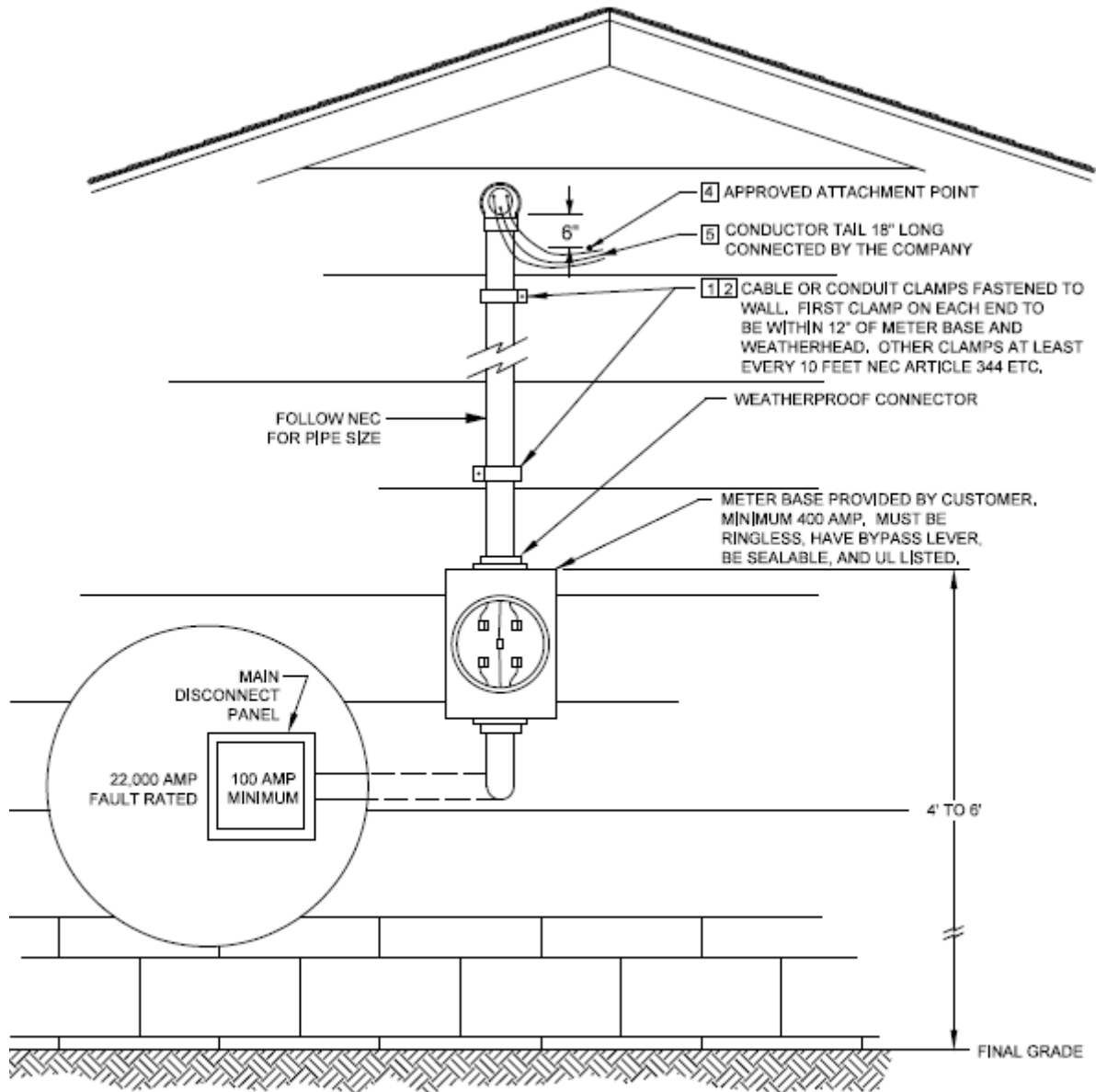

4-1.2 Overhead 100-200 Amp - Option 2

Specifications:

- Ringless Type Meter Socket
- Outdoor Enclosure (Nema type 3R)
- 1 Phase, 3-Wire
- 4 Jaw Meter Socket
- Horn Bypass
- Sealable
- No cover over meter
- UL Listed

PER NESC 234C3D (EXCEPTION 2), THIS MINIMUM IS 18" FOR 120/240, IF CONSIDERED AN INACCESSIBLE ROOF, 18" MINIMUM APPLIES FOR 6' RADIUS OF PERISCOPE. CLEARANCE BEYOND THAT IS 3' PLUS SAG ADDERS. A BACK GUY IS REQUIRED.

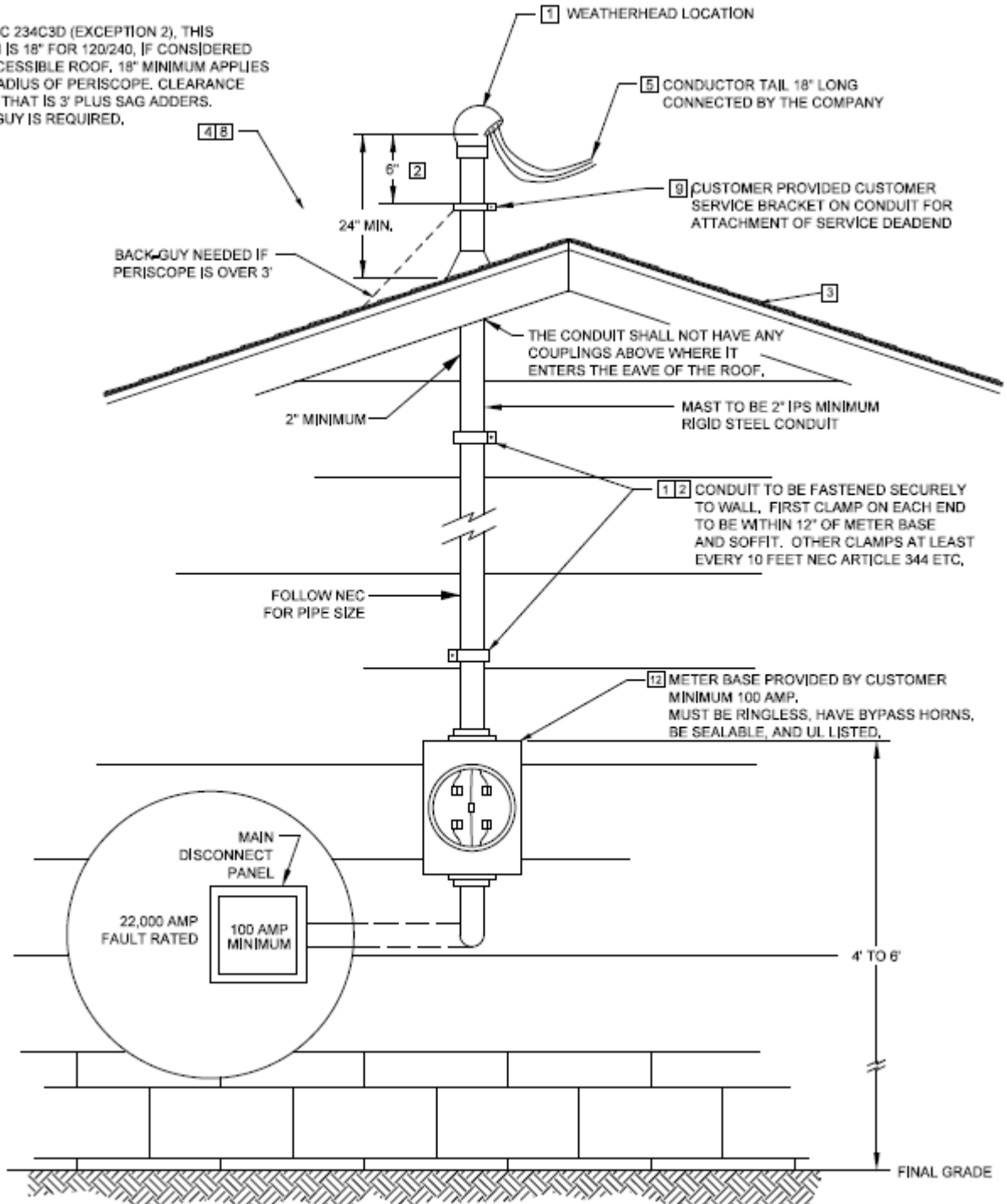

4-1.3 Overhead 320 Amp

Specifications:

- Ringless Type Meter Socket
- 320A Continuous, 400A Max
- Rated 600V AC
- 1 Phase, 3-Wire
- UL Listed
- 4 Jaw Meter Socket
- Bypass Lever
- Sealable
- No cover over meter

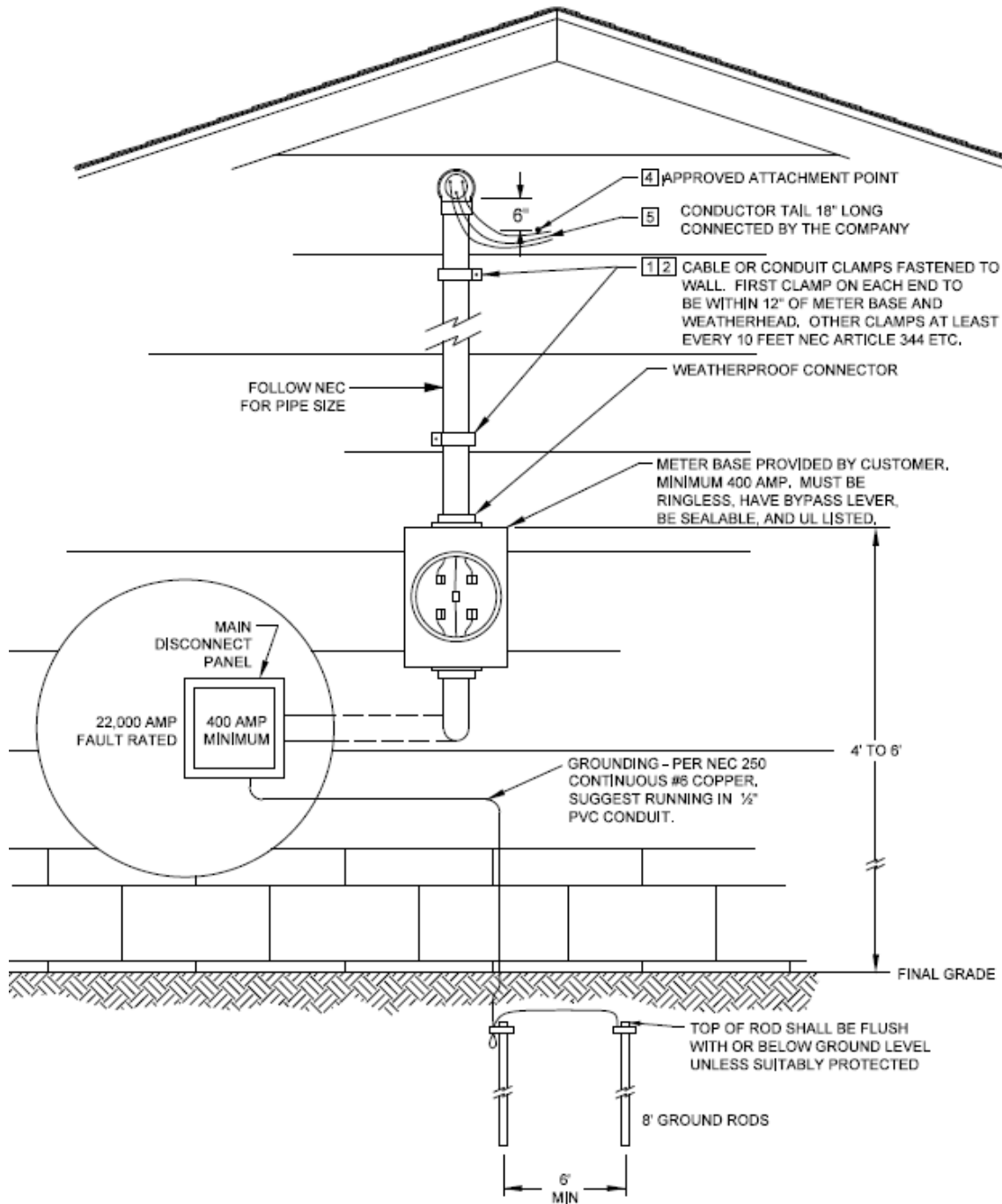

## 4-2 Underground Service Requirements

See Section 3-2 for General Metering Requirements.

See Appendix A for a list of approved meter sockets and pedestal extensions.

1. A pedestal-style meter base shall be used for all meter sockets attached to buildings due to frost heave issues and soil settling around new foundations.
2. All meter sockets shall have adequate space to allow for slack cable and have a bending radius capable of accommodating 350 kcm cable.
3. The meter socket shall be installed 4-6 ft above ground and be readily accessible to be read, tested, and inspected.
4. A pedestal cannot be used for customer-owned wire other than the service entrance cable per NEC 230.7. The Company does not allow the customer ground to be located in the pedestal with the service entrance cables.
5. For free-standing applications (200A only), a minimum of an 8-foot, pressure-treated 6x6 or 4x6 is required and must be buried at least 48 inches with a support 'cookie' or 16-inch treated 2x6 below grade as a base.
6. A disconnect is needed on the meter pedestal if the service entrance conductor extends into the building longer than permitted by NEC 230.70(A). It is also acceptable to use a standard pedestal with a separate weatherproof disconnect.
7. The Company may require conduit for services under driveways and parking lot – see Underground Service Installation, Section 3-1.9
8. Due to ground settling concerns, it is necessary for the customer to provide adequate compaction for disturbed soils below 30 inches. This is soil below the normal underground service burial depth and must be done with sand or gravel. Frozen material and non-compacted clay are not acceptable. See also NEC 300.5(J).

4-2.1 Underground 200 Amp - Pedestal - Standard

Specifications:

- Ringless Type Meter Socket
- Outdoor Enclosure (Nema type 3R)
- 1 Phase, 3-Wire
- 4 Jaw Meter Socket
- Horn Bypass
- Sealable
- No cover over meter
- UL Listed

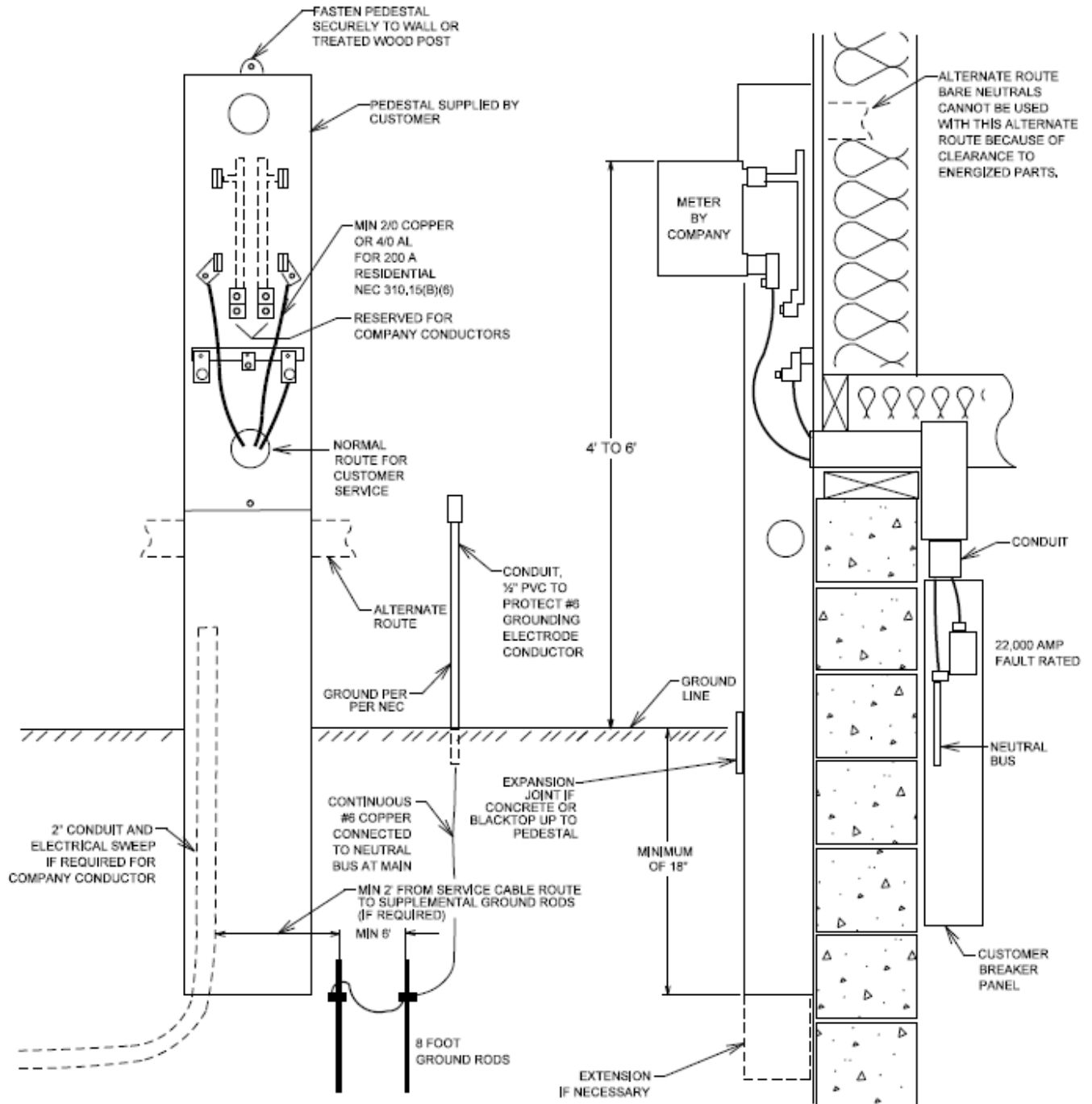

4-2.2 Underground 320 Amp

**Specifications**

- Ringless Type Meter Socket
- 320A Continuous, 400A Max
- Rated 600V AC
- Outdoor Enclosure (Nema type 3R)
- 1 Phase, 3-Wire
- 4 Jaw Meter Socket
- Bypass Lever
- Sealable
- No cover over meter
- UL Listed

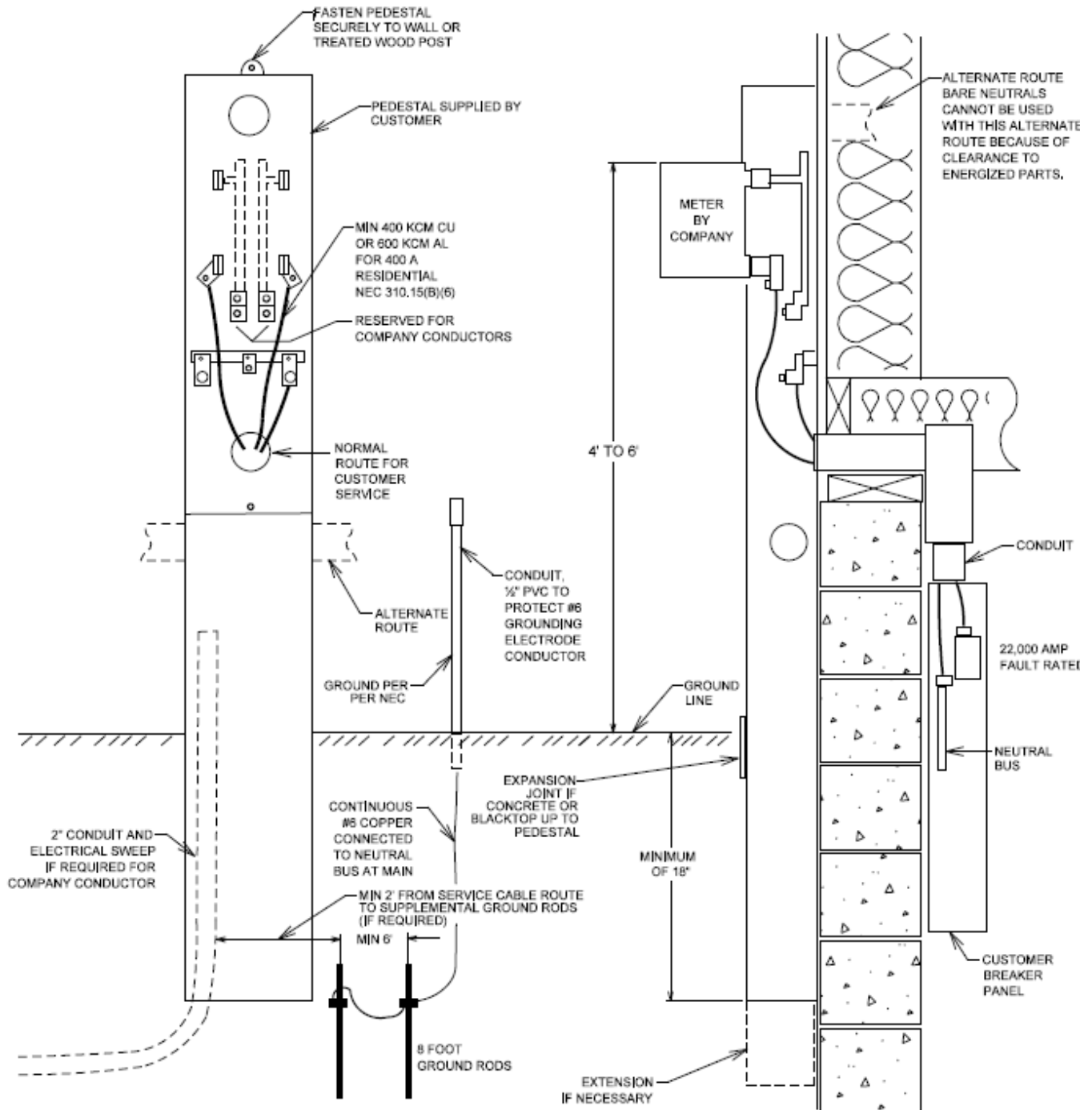



# UPPCO SERVICE MANUAL

Revised 10/21

## Section 4 Single-Phase Metering

Page 9 of 15

### 4-3 Services 400-800 Amp – CT Metering

See Section 3-2 for General Metering Requirements.

See Section 5-6 for meter base and CT cabinet mounting options and general notes.

The Company encourages a three-phase service for installations greater than 400A.

For Services 400A and greater, CT metering is required.

When CT metering is not located in/on the transformer, a CT cabinet is required.

1. The customer shall provide the CT cabinet and meter socket.
2. The CT cabinet shall be mounted outside.
3. The Company requires that all main disconnects rated over 400 Amp be provided with a means of locking the disconnect in the open position. This meets the MIOSHA Rule 408.14004 lock-out procedure.
4. See Appendix B for Fault Current information.

#### **Instrument Transformer-Rated Meter Sockets (for CT installations)**

“CC” 6 Terminal for 120/240 single phase.

Manufacturer	“CC”
Milbank	UC7532-XL
Durham	STS6-2B

#### **Current Transformer Cabinets**

Style of cabinet “A” With CTs mounted vertically, bottom in & top out  
 “B” with CTs mounted vertically, bottom in & top or bottom out  
 “C” With CTs mounted horizontally  
 “D” Stepped termination style with CTs horizontal

Galva Closure also goes by RJB.

EMI stands for Electro-Mechanical Industries

AMP stands for American Midwest Power

400 AMP CT	Style Cabinet	Manufacturer	Catalog #	Dimensions (“)	Fault Rating	Conduit	
3-Wire	A	Erickson	WE1182-3	45.5x20x7.25	42,000	1-3”	
	A	Galva-Closure	UPP-403UG	42x20x8.5	65,000		
	A & B	Galva-Closure	UPP-403UGBX	48x25x15	65,000		
	A	EMI	CTB146-WPS	48x30x10	65,000		
	B	AMP	WPSCT4-3TM	48x36x15	85,000		
	D	AMP	WPSSB8-3ACT	60x33x13	65,000		
600 AMP CT	Cabinet						
	3-Wire	A	Erickson	WE283-USG	48x48x11	65,000	1-4”
	A	Galva-Closure	UPP-603UG	54x36x13	65,000		
	C	Galva-Closure	UPP-603UGBX	48x46x13	65,000		
	A	EMI	CTB146-WPS	48x30x10	65,000		
	D	AMP	WPSSB8-3ACT	60x33x12	65,000		
B	AMP	WPSCT68-3TM	48x36x15	85,000			
800 AMP CT	Cabinet						
	3-Wire	A	Erickson	CUCT-81	48x48x11		2-4”
	A	Galva-Closure	UPP-803UG	54x36x13	65,000		
	C	Galva-Closure	UPP-803UGBX	48x46x13	65,000		
	A	EMI	CTB180-WPS	60x34x18	65,000		
	D	AMP	WPSSB8-3ACT	60x33x13	65,000		
B	AMP	WPSCT68-3TM	48x36x15	85,000			

\* CT cabinets rated at 2000 Amp and higher shall accommodate split bar configuration CT's.

### 4-4 Overhead Service - Meter Poles/Posts

1. Customer must furnish, mount, and maintain all service entrance equipment and set pole/post in the ground. The pole/post location, height, and burial depth to be determined by the Company and coordinated with customer prior to installation.
2. The pole/post must be plumb and sufficiently back guyed/anchored by the customer if greater than 10 feet from the Company pole.
3. If the structure is defined as non-permanent (mobile home or a manufactured home that is not on a foundation), the customer-owned meter pedestal/pole/post must be within sight of and not more than 30' from the exterior wall of the structure (NEC 550.32(A)).

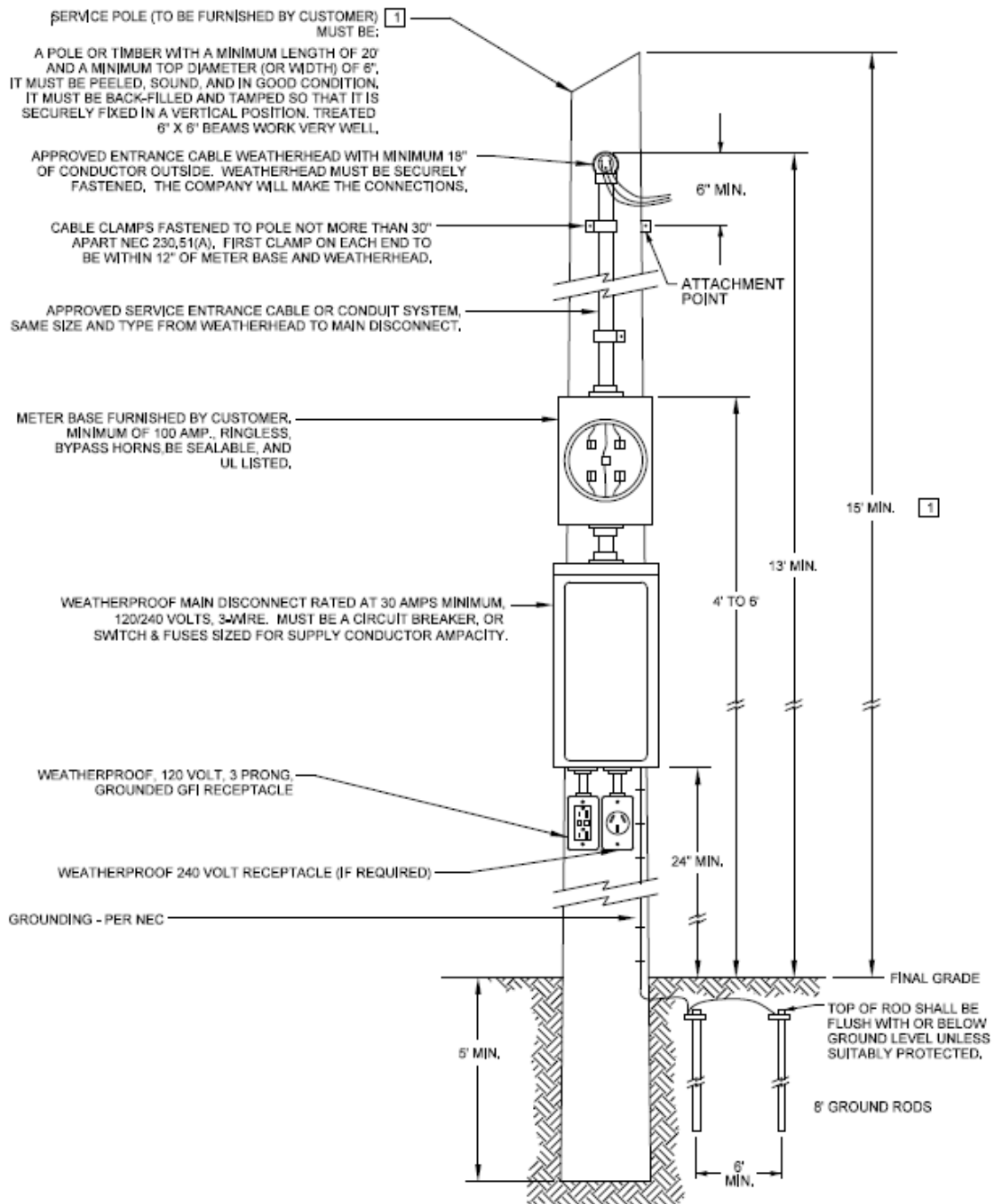

### 4-5 Mobile Home Services

This section also applies to manufactured homes that are not on a foundation and other non-permanent structures. See Appendix B for a full definition.

For overhead service entrances, see Section 4-4 – Meter Pole/Post.

See Appendix A for a list of approved meter sockets and pedestal extensions.

1. The Company requires that all new mobile home parks be built with an underground electrical system.
2. The Company shall designate the service location.
3. The meter must face toward the driveway or street and away from the mobile home.
4. Meters shall not be fastened to mobile homes. [NEC 550.32(A)].
5. The Company requires a substantial support (treated wood posts) as per the below specification.
6. Metering pedestals and associated means of disconnect shall be labeled as to which premise is fed from the pedestal (NEC 110.22).
7. The customer-owned meter pedestal/pole/post must be within sight of and not more than 30' from the exterior wall of the mobile home and no less than 100A (NEC 550.32(A)).

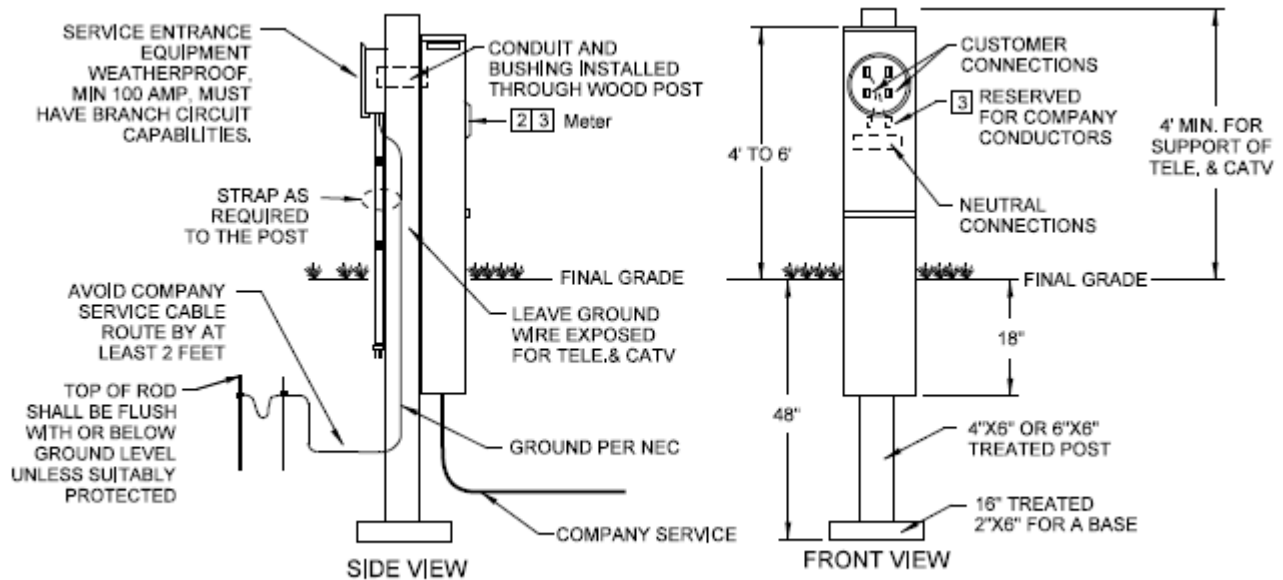

### 4-6 Temporary Services/Construction Power

Temporary services are subject to all policies outlined in Section 3-2 – General Metering Requirements

1. Temporary services are intended for short-term use, defined by the Company as 1 year. After 1 year, the Company reserves the right to require inspection of the temporary service. (NEC 590.3 – no permanent wiring off temp).
2. Customer must furnish and mount all service entrance equipment and the set pole/post in the ground. The pole/post location, height, and burial depth to be determined by the Company and coordinated with customer prior to installation.
3. The pole/post must be plumb and sufficiently backguyed/anchored by the customer if greater than 10 feet from the Company pole. An alternative is the use of two 2" x 4" push braces staked into the ground.
4. If the structure foundation is in place, a temporary service may not be necessary. See Option 4 below and Section 4-2 on underground service requirements.

#### (Option 1, Overhead)

Service pole (to be furnished by customer)  
Must be:

A treated pole or treated timber with a minimum length of 20' and a minimum and a minimum top diameter (or width) of 6". It must be peeled, sound and in good condition. It must be back-filled and tamped so that it is securely fixed in a vertical position. Treated 6"x6" beams work well.

Approved entrance cable weather head with minimum 18" of conductor outside. Weather head must be securely fastened. The Company will make the connections.

Cable clamps fastened to pole not more than 30" apart, NEC 230.51 (A). First clamp on each end to be within 12" of meter base and weather head.

Approved service entrance cable or conduit system. Same size and type from weather head to main disconnect.

Meter base furnished by customer. Minimum of 100 amp, ringless, bypass horns, sealable and UL listed.

Weatherproof main disconnect rated at 30 amps minimum. 120/240 volts, 3-wire. Must be a circuit breaker or switch & fuses sized for supply conductor ampacity.

Weatherproof, 120v, 3 prong, grounded GFCI receptacle.

Weatherproof 240 volt receptacle (if required)

Grounding – Per NEC

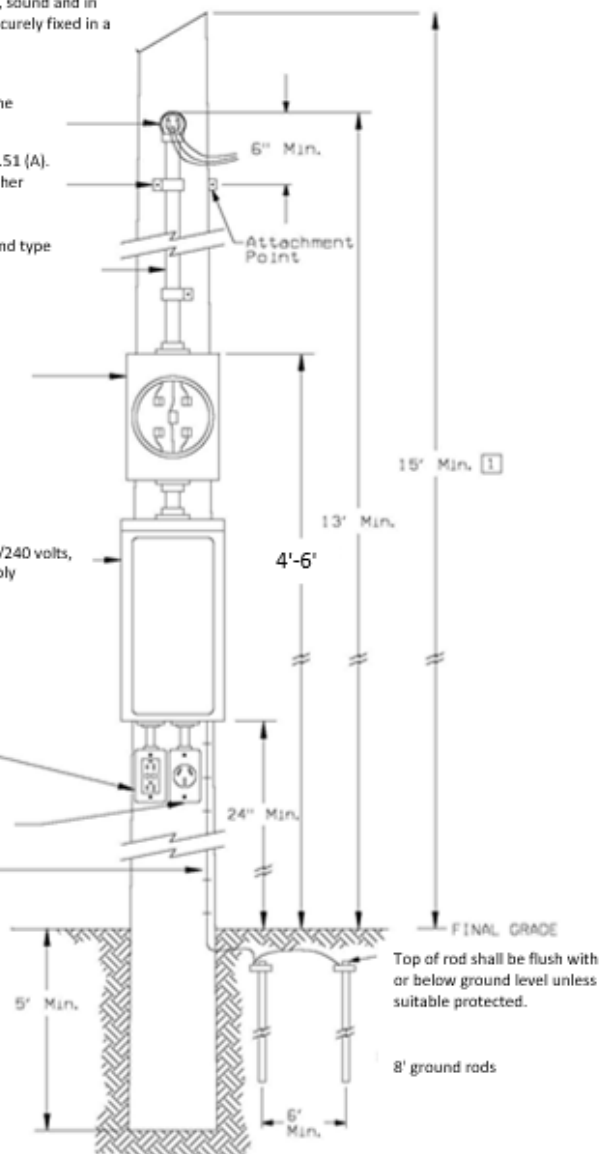

**UPPCO SERVICE MANUAL**

Revised 10/21

**Section 4 Single-Phase Metering**

Page 13 of 15

(Options 2 through 4, Underground)

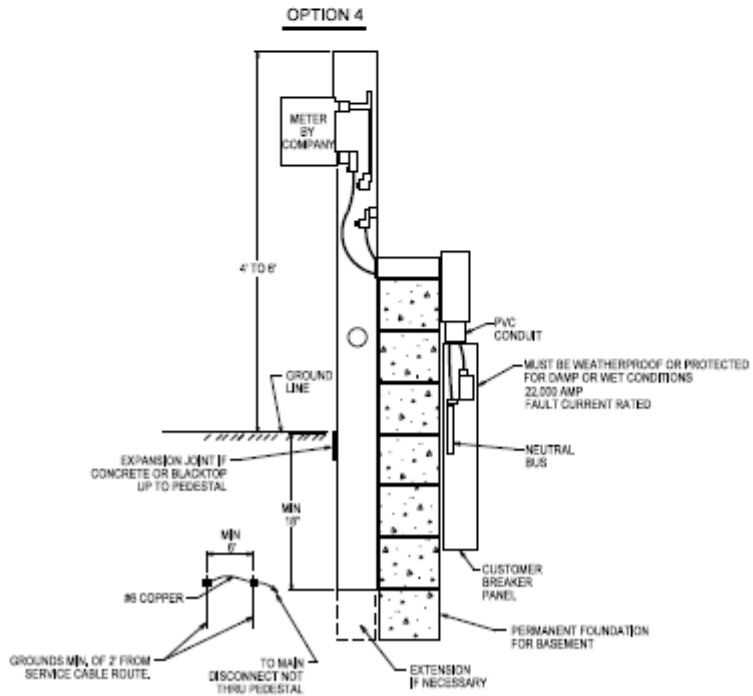
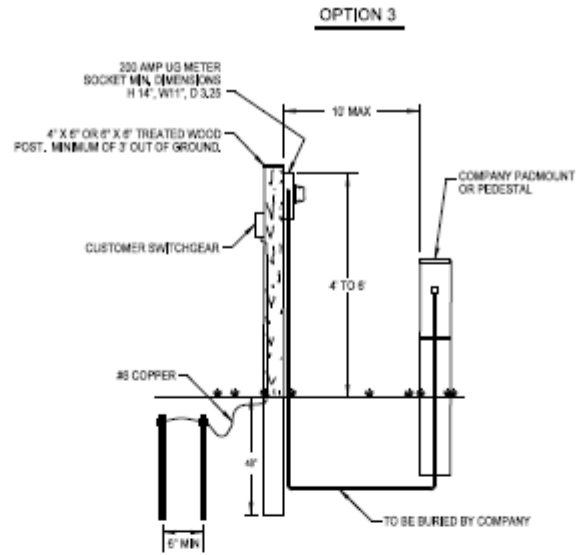
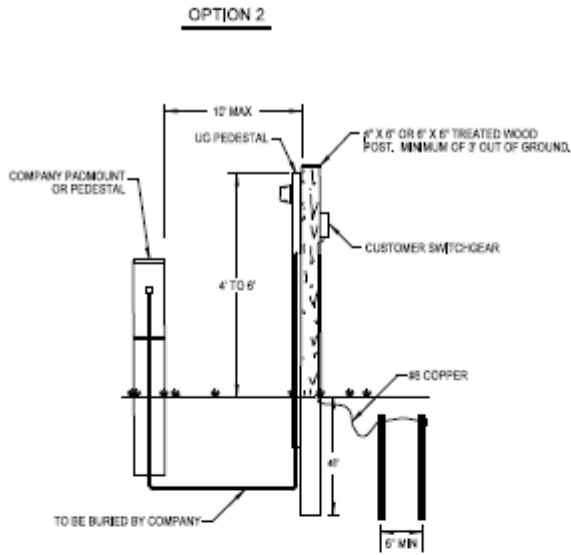

Self-supported meter base example:



## 4-7 120/208 Volt Service (100-200 Amp)

1. This is for single-phase applications, such as apartments, that are fed from a three phase service.
2. Single-phase service drop application shall be limited to 200 Amp. Larger installations shall have a three-phase service drop with the single-phase meters and connected loads balanced on all phases.
3. A fifth jaw can be added to most new-style, single-phase 120/240V meter sockets for 120/208V single-phase service. The fifth jaw shall be securely attached in the 9 o'clock position as pictured below.
4. Existing installations with the fifth jaw in the 6 o'clock position or with a wire jumper between the meter and the meter socket shall be corrected when upgrading the wiring.

